

European PM Tests
HP 11807A,E Option 002
Reference Guide
for the HP 8920A,B

HP Part No. 11807-90117
Printed in U. S. A.
April 1995

Revision B

RESTRICTED RIGHTS LEGEND

Copyright © Hewlett-Packard Company 1995

RESTRICTED RIGHTS LEGEND

Use, duplication or disclosure by the U.S. Government is subject to restrictions as set forth in subparagraph (c) (1) (ii) of the Rights in Technical Data and Computer Software clause in DFARS 252.227-7013.

Hewlett-Packard Company
3000 Hanover Street
Palo Alto, CA 94304
U.S.A.

Rights for non-DOD U.S. Government Departments and Agencies are as set forth in FAR 52.227-19 (c) (1,2).

Contents

1 Product Description

HP 11807A,E Software 16

Finding the Information You Need 18

Additional Services Available 19

Contents

A.14.00	2 Using the Software/HP 8920B, or HP 8920A FW Above Rev
	Testing Overview 24
	Customizing Testing 30

Contents

3 Using the Software/HP 8920A FW Rev Below A.14.00

Testing Overview 58

Customizing Testing 64

Contents

Descriptions

4 Test, Parameter, and Pass/Fail Limit (Specification)

Introduction	90
TEST_01. TX and RX Stand-by Current Drain	91
TEST_02. TX Frequency Error	92
TEST_03. TX Output Power Error	93
TEST_04. TX Modulation Limiting	94
TEST_05. TX Frequency Deviation	95
TEST_06. TX Audio Frequency Response	96
TEST_07. TX Audio Distortion	97
TEST_08. TX Microphone Sensitivity	98
TEST_09. TX Residual Modulation	99
TEST_10. TX CTCSS/CDCSS Deviation, Freq/Code	100
TEST_11. RX Noise and Hum	101
TEST_12. RX Audio Distortion	102
TEST_13. RX Frequency Response	103
TEST_14. RX Usable Sensitivity	104
TEST_15. RX Amplitude Characteristics	105
TEST_16. RX Audio Squelch Sensitivity	106
TEST_17. RX CTCSS/CDCSS Opening	107
TEST_18. RX Quick Test	108

Contents

TEST_19. TX Quick Test	109
Test Parameter Descriptions	110
Parameter 1. AS Rated Carrier Output Power	111
Parameter 2. AS Rated Carrier Output Power Low Switch	112
Parameter 3. RT Channel Spacing	113
Parameter 4. RT External Pad and Cable Loss	114
Parameter 5. RT Full Rated System Deviation	115
Parameter 6. RT High Supply Voltage	116
Parameter 7. RT Low Supply Voltage	117
Parameter 8. RT Nominal Supply Voltage	118
Parameter 9. RT Test At Extreme Settings	119
Parameters 10-11. RX Amplitude Characteristic RF Level 1 and 2	120
Parameters 12-13. RX Audio Distortion RF Level 1 and 2	121
Parameter 14. RX Audio Freq Response Step Frequency	122
Parameter 15. RX Audio Load Impedance	123
Parameter 16. RX CT/CDCSS Available/Control	124
Parameter 17. RX CT/CDCSS Deviation	125
Parameter 18. RX Nominal Audio Power	126
Parameter 19. RX Set Radio Volume	127
Parameter 20. RX Squelch Control	128

Contents

Parameter 21. RX Squelch Preset Only	129
Parameter 22. RX Tolerance For Setting Volume	130
Parameter 23. RX Usable Sens Set And Meas	131
Parameter 24. RX Usable Sensitivity SINAD Level	132
Parameters 25-27. TX Audio Freq Response Start, Stop and Step Frequencies	133
Parameter 28. TX CT/CDCSS Available	134
Parameter 29. TX CTCSS/CDCSS Control	135
Parameter 30. TX CT/CDCSS Filter 1 Opt	136
Parameter 31. TX De-emphasis	137
Parameter 32. TX Dekey Between TX Tests	138
Parameters 33-35. TX Freq Dev Start, Step, and Stop Freq For Audio Band	139
Parameter 36. TX Freq Dev Tested >3 kHz	140
Parameter 37. TX Mic Sensitivity Level	141
Parameter 38. TX Output Power @Low Switch	142
Parameter 39. TX User/System Key UUT	143
Parameter 40. XX Secure Frequency Info	144
Pass/Fail Limit (Specification) Descriptions	145
Pass/Fail Limit 1. RX Amplitude Characteristics Change	146
Pass/Fail Limit 2. RX Audio Distortion	147

Contents

Pass/Fail Limit 3. RX Audio Freq Resp Delta From 6 dB/oct	148
Pass/Fail Limit 4. RX CT/CDCSS Opening Level	149
Pass/Fail Limit 5. RX CT/CDCSS SINAD At Opening	150
Pass/Fail Limit 6. RX Noise and Hum	151
Pass/Fail Limit 7. RX SINAD Audio Level Change at Extremes	152
Pass/Fail Limit 8. RX Stand-by Current Drain	153
Pass/Fail Limit 9. RX Threshold Squelch Sensitivity	154
Pass/Fail Limit 10. RX Tight Squelch Sensitivity	155
Pass/Fail Limit 11. RX Usable Sensitivity	156
Pass/Fail Limit 12. RX Usable Sensitivity At Extremes	157
Pass/Fail Limit 13. TX Audio Distortion	158
Pass/Fail Limit 14. TX Audio Modulation Index Error	159
Pass/Fail Limit 15. TX CT/CDCSS Deviation	160
Pass/Fail Limit 16. TX CTCSS Frequency Error	161
Pass/Fail Limit 17. TX Current Drain	162
Pass/Fail Limit 18. TX Frequency Deviation	163
Pass/Fail Limit 19. TX Frequency Error	164
Pass/Fail Limit 20. TX Mic Sensitivity	165
Pass/Fail Limit 21. TX Modulation Limiting	166
Pass/Fail Limit 22. TX Output Power Error	167

Contents

Pass/Fail Limit 23. TX Output Power Error @ High Supply 168

Pass/Fail Limit 24. TX Output Power Error @High Supply Lo
SW 169

Pass/Fail Limit 25. TX Output Power Error @Low Supply 170

Pass/Fail Limit 26. TX Output Power Error @Low Supply Lo
SW 171

Pass/Fail Limit 27. TX Output Power Error Low Switch
Setting 172

Pass/Fail Limit 28. TX Residual Modulation 173

5 Reference (Alphabetical)

Conventions Used 176

Copying Files 177

Data Collection (Saving and Retrieving Test Results) 179

Disks 189

Exiting a Program 191

HP-IB Control Annunciators 192

Memory Cards 193

Parameters 200

Pass/Fail Limits (specifications) 201

Pausing or Stopping a TEST 202

Printing 203

Procedures 216

RAM 222

Saving Tests Results 224

Serial Port 225

Test Execution Conditions 227

USER Keys 229

6 Problem Solving

If You Have a Problem Testing Your Radio 232

If the test procedure doesn't run on test set 233

If the HP 11807A,E program was incorrectly loaded 234

If the printer does not print the test results 235

If the PM radio fails the audio tests 237

If radio volume can't be set on the test set's meter screen 238

If your radio fails CTCSS/CDCSS tests or the tests don't run 239

If you can't get the data-collection function to work 242

Contents

Glossary 245

Contents

Index 249

Product Description

|

HP 11807A,E Software

The HP 11807A,E Option 002, Radio Test Software is used for automated testing of f radios. Software is written on One-Time Programmable (OTP) memory cards shown below. The Test Set's built-in computer (operating with HP Instrument BASIC programming language) allows automated measurements for quick-functional, or full-parametric testing.

- Quick-functional testing of f M radios is done using the pre-written Test Procedure “EUROPE_PM” on the OTP memory card.
- Also, user-defined Test Procedures may be created for full-parametric testing to meet your radio-specific testing needs. The user-defined Test Procedures are saved onto the Static Random-Access Memory (SRAM) memory card which is provided with each HP 11807A,E option.

Materials Included in This Package

This package contains the following materials. Verify that all of the materials are present and inspect for damage. If a part is missing or appears to be damaged, contact your nearest Hewlett-Packard sales or service office.

- HP 11807A Option 002 Test Software (part number 11807-10002) or HP 11807E Option 002 Test Software (part number 11807-10021).
- SRAM memory card (uninitialized), for saving your own test procedures and results.
 - For HP 11807A, 32 Kbyte SRAM (part number HP 85700A).
 - For HP 11807E, 64 Kbyte SRAM (part number HP 83230A).
- HP 11807A,E Option 002 Software User's Guide (part number 11807-90117).
- HP software product license agreement

Additional Equipment Required

The HP 11807A,E Option 002 software requires the Test Set to be configured with the following hardware:

- 256k RAM Memory extension, HP 8920A Option 005

Recommended Equipment

Other hardware configurations for your Test Set are recommended, but not required:

- High-Stability Timebase, HP 8920A,B Option 001
- Tone/Digital Signaling, HP 8920A,B Option 004
- 400 Hz High-Pass Filter, HP 8920A,B Option 010
- CCITT Weighting Filter, HP 8920A,B Option 011

External Power Supplies

An external power supply for the Φ M radio can be configured to the Test Set in one of three ways:

1. A power supply or battery can be connected directly to the f M radio.
2. A power supply can be connected to the rear-panel DC CURRENT MEASUREMENT banana-plug connectors. (This requires the HP 8920A Option 003, HP-IB/RS-232/dc Current Measurement.)
3. A power supply can be controlled by the Test Set when it's connected to the HP-IB connector. (This requires the HP 8920A Option 003, HP-IB/RS-232/Current Measurement.)

HP-IB programmable power supplies from the following series are supported for external control:

HP 664xA
HP 665xA
HP 667xA
HP 668xA

NOTE:

HP 662xA and HP 663xA series DC power supplies are not supported.

Pad and Cable Loss. Use [parameter Parameter 4. RT External Pad and Cable Loss](#) to compensate for any attenuator (pad) or cable losses from the f M radio to the Test Set.

Ordering Upgrades

If your test set does not contain all of the required options you must update your instrument accordingly. Order the necessary upgrade kit(s) from your local Hewlett-Packard sales office. Regional sales offices are listed at the front of this manual.

Finding the Information You Need

This manual describes the setup and use of the HP 11807A,E Software with the HP 8920A,B,D Test Set. The book is arranged in self-contained chapters to provide the following information:

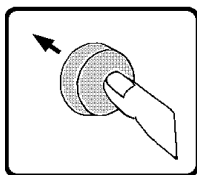

PRODUCT DESCRIPTION CHAPTER 1

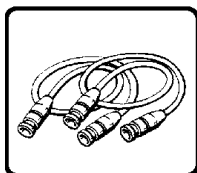

USING THE SOFTWARE-CHAPTER 2

- Instructions for cabling test set.
- How to load
- How to run
- How to customize

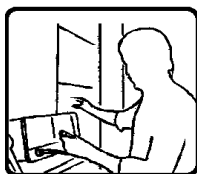
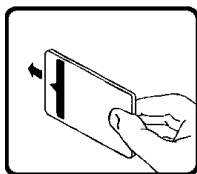

TEST DESCRIPTIONS-CHAPTER 4

Definitions, special conditions and restrictions for:

- Tests
- Pass/fail limits
- Parameters

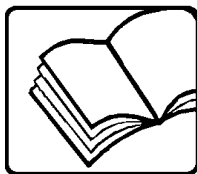

REFERENCE-CHAPTER 5

- Alphabetically listed
- Detailed descriptions of all the features and functions of the software.
- For the advanced level user.



PROBLEM SOLVING-CHAPTER 6

- Alphabetically listed
- Symptoms and possible corrections to frequent user problems.

MANUAL1

Additional Services Available

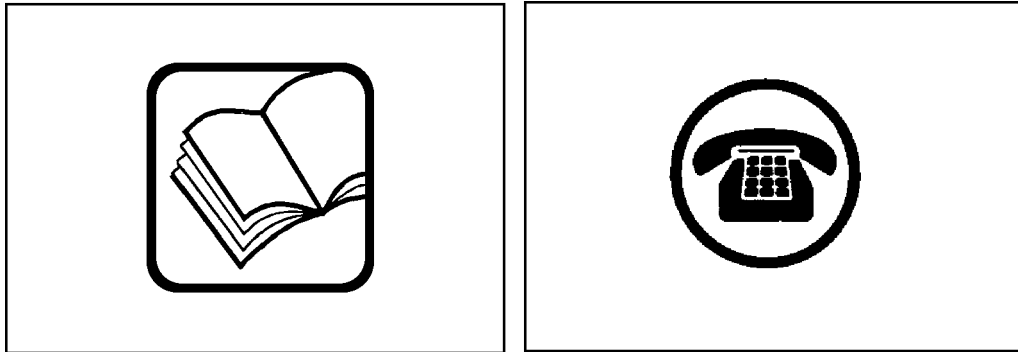

TROUBLE1

Consult the HP 8920 User's Guide or call the HP 8920 Hotline 1-800-922-8920 (in the USA and Canada only) and give your software model number.

**Using the Software/HP 8920B, or HP
8920A FW Above Rev A.14.00**

NOTE:

The firmware revision A.14.00 in the HP 8920A,D had several enhancements, which are standard in the HP 8920B. This chapter applies to users with:

- **HP 8920A test sets with firmware revision above A.14.00**
- **All HP 8920B test sets.**

The test set's firmware revision is displayed on the top right corner of the configuration screen.

- Press SHIFT CONFIG to display the configuration screen and read the firmware revision.

If you have an HP 8920A test set with firmware revision below A.14.00, refer to [chapter 3, "Using the Software/HP 8920A FW Rev Below A.14.00," on page 55](#). Contact Hewlett-Packard at 1-800-922-8920 for details on upgrading your firmware if desired.

The software can be run on the factory default settings or customized to your individual needs and specific requirements. This chapter provides detailed information on how to load, run, and customize the software.

The test set has two methods of accessing on-line help. In each of the screens in the test environment, **k4 (He1p)** accesses specific information about how to set up/use the current screen. **SHIFT HELP** accesses the master help file, with an alphabetical listing of help topics.

Testing Overview

Pressing TESTS will display what is called the TESTS (Main Menu) screen. To begin testing, you must first load the software and make connections. From this screen you have the option to:

Begin running tests:

- The factory default settings are acceptable for your application or
- The software has already been customized and saved to a memory card

Customize the software:

- Decide which tests you desire to run (Order of Tests)
 - you may want to run all, some, or just one of the tests.
- Specify which channels to test (Channel Information)
 - you may want to test one, some, or all of the channels on your radio.
- Change the pass/fail limits for specific measurements (Pass/Fail Limits)
 - you may want the pass/fail limits to have tighter or looser specifications than the default settings.
- Change the test environment and conditions (Test Parameters)
 - decide output format.
 - enter specific information about radio equipment and/or environment.
- Save any or all of the above customized changes to a memory card (Save/Delete Procedure)

Set Up Test Set:

- Print test results or certain screens.
- Decide when and where test results are displayed (**Execution Conditions/Printer Setup**)

To Run Tests

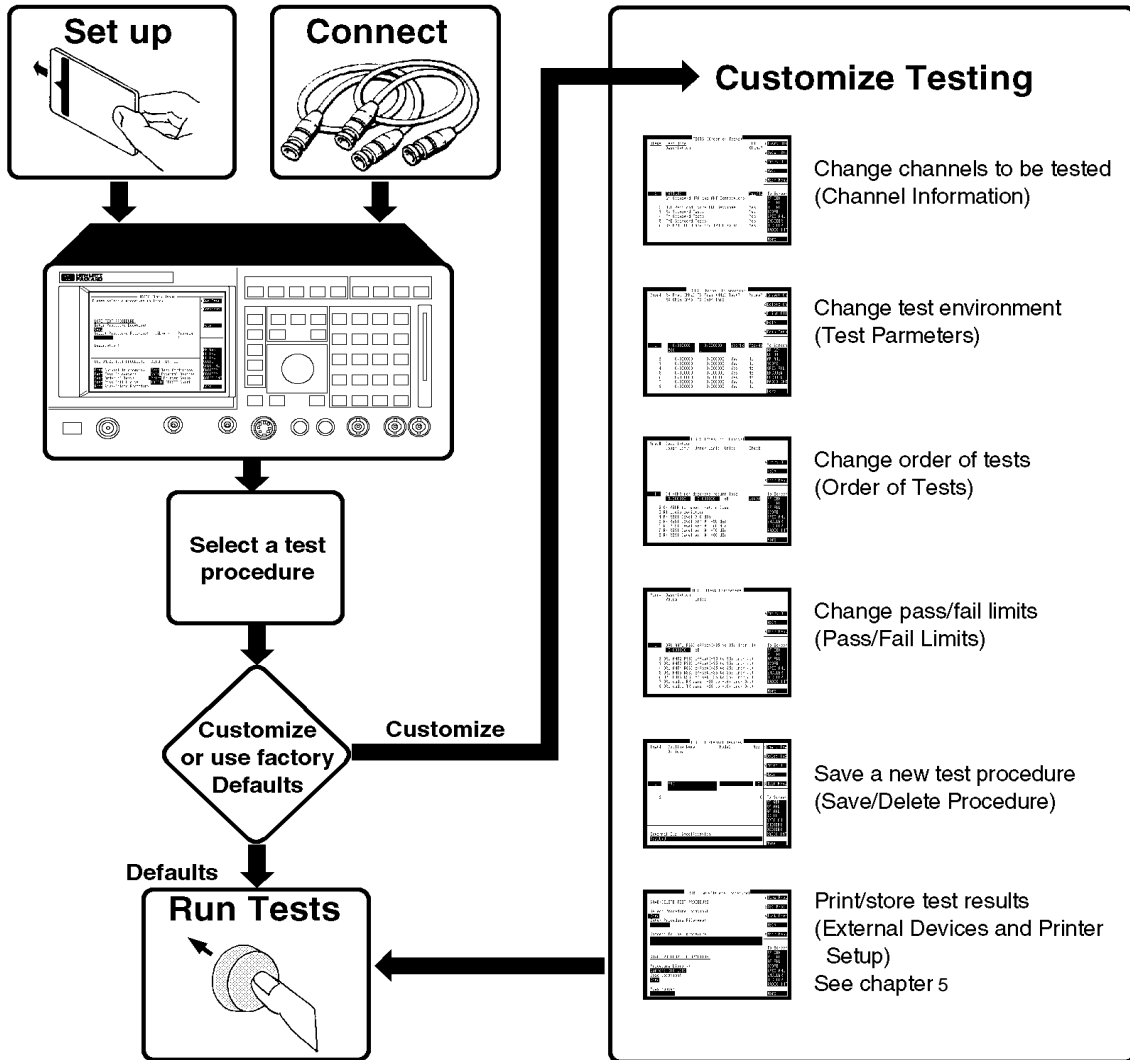

OVERVIEW1

Setting Up the Test Set and Making Connections

Before you begin testing, you must set up the test set and make the appropriate hardware connections.

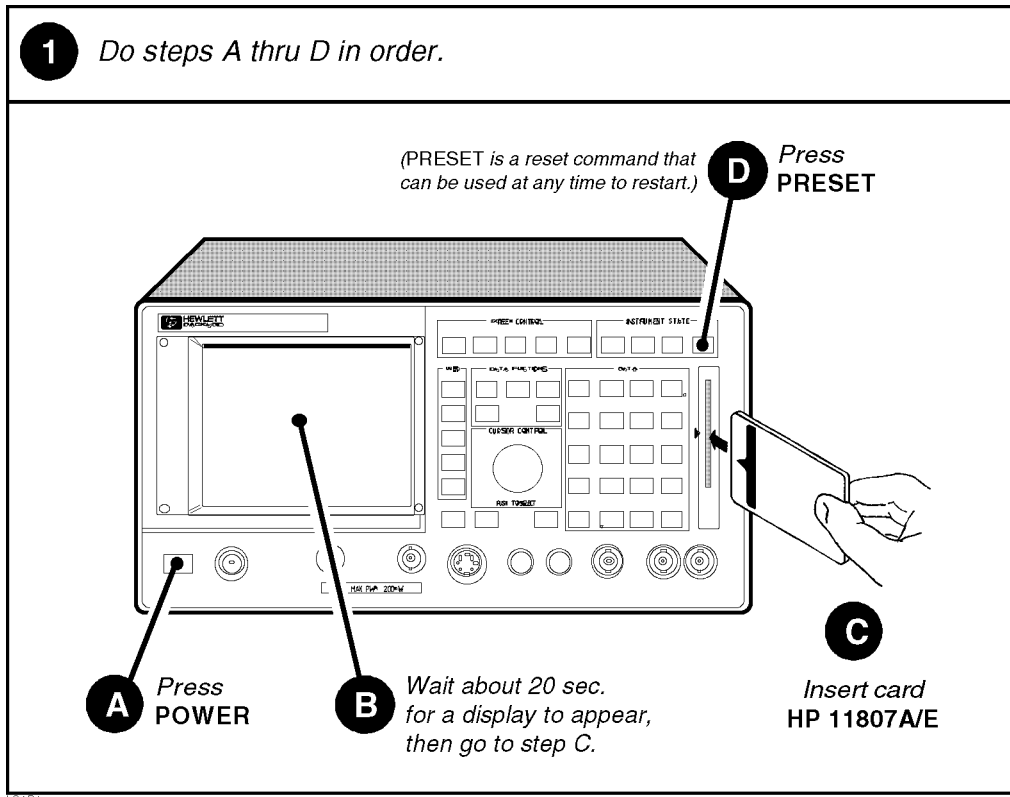

Making a Connection

2 Connect a radio to the test set.

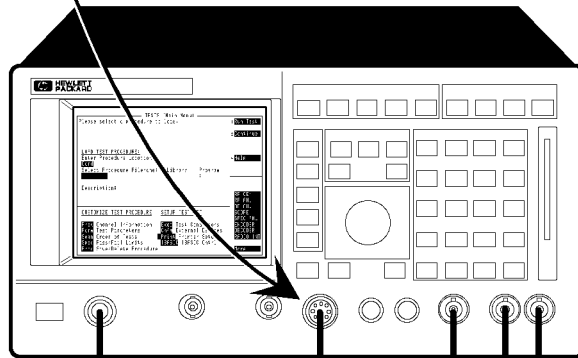
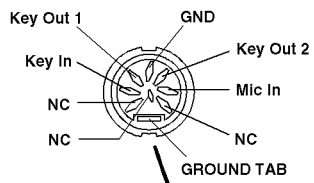

A load is needed if the UUT speaker is disconnected.

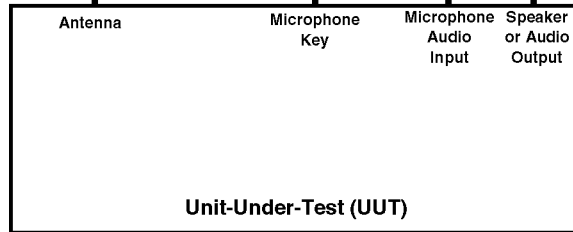

CONNECT1

Selecting a Test Procedure









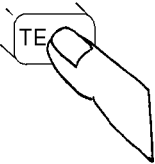

To load the software, you must first select the location to load from (in this case, it will be **Card**) and a procedure filename. Your card comes pre-programmed with at least one procedure. The actual software program does not get loaded into the test set's memory until k1 (**Run Test**) is selected. It will take approximately 15 seconds to load the software in an HP 8920B, and approximately two minutes in an HP 8920A.

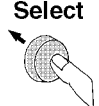
The software memory card can be removed after the program is loaded into the test set's memory. The program will remain in memory after a power-down/ power-up cycle, unless it is manually deleted or a new program is loaded.

When tests begin to run, they are executed in the order in which they were entered into the Test Procedure.

Pressing CANCEL will pause the current test (press k2 to continue the test.)

Selecting A Test Procedure

<p>1 Press TESTS to display the TESTS screen.</p>	<p>2 Position cursor and select Select Procedure Location:.</p>
<p>If you are in IBASIC, press SHIFT, CANCEL before pressing TESTS.</p> 	<p>Position</p>  <p>Select Procedure Location:</p> 
<p>3 Position cursor and select Card.</p>	<p>4 Position cursor and select Select Procedure Filename:.</p>
<p>Position</p>  <p>Select</p>  <p>Choices :</p> <ul style="list-style-type: none"> <input checked="" type="checkbox"/> Card ROM RAM Disk 	<p>Position</p>  <p>Select Procedure Filename:</p> 
<p>5 Position cursor and select desired Procedure.</p>	<p>6 Position cursor and select Run Test.</p>
<p>Position</p>  <p>Select</p>  <p>Choices :</p> <ul style="list-style-type: none"> <input checked="" type="checkbox"/> XXXXXX XXXXXX XXXXXX XXXXXX 	<p>Position</p>  <p>Select</p>  <p>8920A,D ≈ 2 min. 8920B ≈ 15 sec.</p> <ul style="list-style-type: none"> <input checked="" type="checkbox"/> Run Test 2 Continue 4 Help

PROCE01

Customizing Testing

Because of the diversity of individual testing needs, the software has been designed so that changes may be easily made from the test set's front panel. You may store these changes on a memory card so that you may skip these steps in the future. See **"Saving a Test Procedure" on page 48**.

Because your needs change, the software allows changes to its default settings whenever you need to make them. For example, tests may be inserted or deleted, and later after running the tests you can change the pass/fail limits or decide to test different channels.

Most testing customization is accomplished through the customization screens. These customization screens are accessed from the main TESTS (Main Menu) screen as shown in the following figure. Customizing procedures is explained later in this chapter.

NOTE:

External Devices, Printer Setup, and IBASIC will not be explained in this customizing section.

- External Devices and Printer Setup are used when setting up printers and external disk drives which is explained in **"Disks" in chapter 5 on page 189** and **"Printing" in chapter 5 on page 203**.
- IBASIC is used when writing your own programs and is not explained in this manual. If you need to write your own IBASIC programs you may acquire the following manuals:
 - HP 8920A
 - *HP Instrument Basic User's Handbook* HP part number E2083-90000.
 - *HP 8920A Programming Manual* HP part number 08920-90220.
 - HP 8920B
 - *HP Instrument Basic User's Handbook Version 2.0*
HP part number E2083-90005.
 - *HP 8920B Programming Manual* HP part number 08920-90222.

How to Customize Testing

TESTS (Main Menu) Screen

```
TESTS (Main Menu)
Please select a procedure to load.

LOAD TEST PROCEDURE:
Select Procedure Location:
Card
Select Procedure Filename:  Library:  Program:
Description:

CUSTOMIZE TEST PROCEDURE:  SET UP TEST SET:
Freq Channel Information  Exec Execution Cond
Parm Test Parameters      Cnfg External Devices
Sequ Order of Tests       Print Printer Setup
Spec Pass/Fail Limits     IBASIC IBASIC Cntrl
Proc Save/Delete Procedure

To Screen
RF GEN
RF ANL
AF ANL
SCOPE
SPEC ANL
ENCODER
DECODER
RADIO INT
More

1 Run Test
2 Continue
4 Help
```

Selecting a Test Function opens a Customization Screen.

CUSTOM1a

Changing the Order of Tests











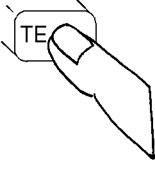



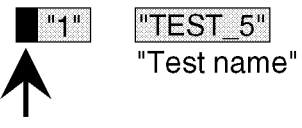

You may define the order of tests to include all, some, or just one of the tests available. When the first test is finished, the next will run. The test sequence will remain in the test set's battery backed-up memory until another test sequence is loaded or set up. For information on saving a customized test sequence, see ["Saving a Test Procedure" on page 48](#).

Defining the order of tests is accomplished by inserting or deleting tests from the list of tests that come with the software package. See [chapter 4, "Test, Parameter, and Pass/Fail Limit \(Specification\) Descriptions" on 89](#), for descriptions of tests included in this package.

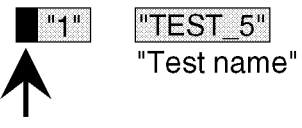
The **All Chans?** field allows the user to decide to run the test on all channels entered in the **Channel Information** table, or just the channels which are selected as **Prime** in the **Channel Information** screen. This feature allows the user the flexibility to use channels that are selected as **Prime** in all the tests in the sequence, and those indicated as non-prime in a subset of tests (those tests with a **Yes** response in **All Chans**). For more information, see ["Specifying Channel Information" on page 36](#).

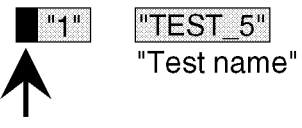







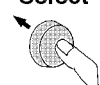

The following describes how to create a new test sequence and enter a response to the **All Chans?** field.

How to Change the Order of Tests

<p>1 Press TESTS to display the TESTS (Main Menu) screen.</p>	<p>2 Position cursor and select Seqn Order of Tests.</p>												
<p>If you are in IBASIC, press SHIFT, CANCEL before pressing TESTS.</p> 	<table border="1"> <tr> <td>Position</td> <td></td> </tr> <tr> <td></td> <td>Freq Channel Information</td> </tr> <tr> <td></td> <td>Parm Test Parameters</td> </tr> <tr> <td>Select</td> <td>Seqn Order of Tests</td> </tr> <tr> <td></td> <td>Spec Pass Fail Limits</td> </tr> <tr> <td></td> <td>Proc Save/Delete Procedure</td> </tr> </table>	Position			Freq Channel Information		Parm Test Parameters	Select	Seqn Order of Tests		Spec Pass Fail Limits		Proc Save/Delete Procedure
Position													
	Freq Channel Information												
	Parm Test Parameters												
Select	Seqn Order of Tests												
	Spec Pass Fail Limits												
	Proc Save/Delete Procedure												
<p>The Order of Tests screen is now present on your CRT.</p>	<p>3 Position cursor and select Step # field.</p> <table border="1"> <tr> <td>Position</td> <td></td> </tr> <tr> <td></td> <td>Example</td> </tr> <tr> <td>Select</td> <td>  </td> </tr> <tr> <td></td> <td></td> </tr> </table>	Position			Example	Select							
Position													
	Example												
Select													
													
<p>4 Rotate knob until Step # which precedes the insertion point of the new test you are adding is highlighted, then select it.</p>													
<p>Rotate</p>  <p>Select</p> 	<p>For example, select step 7 if you want to insert the new test as step 8.</p> <table border="1"> <tr> <td>"7"</td> <td>"TEST_#"</td> </tr> <tr> <td></td> <td>"Test name"</td> </tr> <tr> <td>"8"</td> <td>"New test"</td> </tr> </table>	"7"	"TEST_#"		"Test name"	"8"	"New test"						
"7"	"TEST_#"												
	"Test name"												
"8"	"New test"												

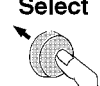
SEQ1

Continue on next page

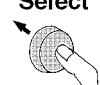
<p>5 <i>Position cursor and select Insrt Stp.</i></p> <p>Position </p> <p>Select </p> <div style="border: 1px solid black; padding: 5px; margin-left: 20px;"> <p>■ Insrt Stp 2 Delet Stp 3 Print All 4 Edit Freq 5 Edit Spec</p> </div>	<p>6 <i>Position cursor back at Step # field and select it.</i></p> <p>Position </p> <p>Select </p> <div style="margin-left: 20px;"> <p>■ "7" "TEST #" "Test name"</p> </div>
<p>7 <i>Highlight and select Step # field of newly inserted test.</i></p> <p>Highlight </p> <p>Select </p> <div style="margin-left: 20px;"> <p>"8" "TEST #" "Test name"</p> </div>	<p>8 <i>Position cursor and select Test Name field.</i></p> <p>Position </p> <p>Select </p> <div style="margin-left: 20px;"> <p>"8" ■ "TEST #" "Test name"</p> </div>
<p>9 <i>Rotate knob and select desired Test Name when it appears.</i></p> <p>Rotate </p> <p>Select </p> <div style="margin-left: 20px;"> <p>"#" "TEST #" "Test name"</p> </div>	<p>10 <i>Position cursor at All Chans? field and select Yes or No.</i></p> <p>Position </p> <p>Select </p> <div style="margin-left: 20px;"> <p>■ Yes/No (Press the knob to change the selection.)</p> </div>

SEQ2

Continue on next page

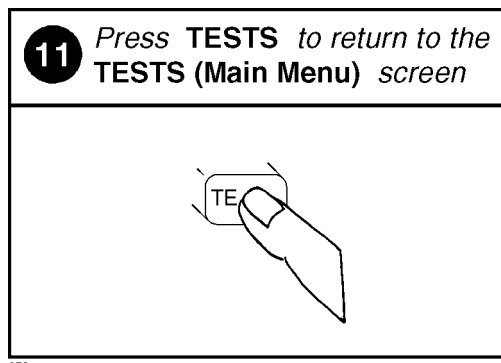

Specifying Channel Information

For each channel that you wish to specify, you must enter the following information into the **Channel Information** screen:

- RX Freq (MHz)
 - Enter the receive frequency of your radio in (MHz).
- TX Freq (MHz)
 - Enter the transmit frequency of your radio in (MHz).

NOTE:

Enter a **-1** in the RX or TX test frequency fields to have all subsequent frequencies ignored when testing is started.

- Sq Freq/Code (for RX Freq)
 - If you are testing receiver CTCSS or CDCSS (test parameter 16 is set=1), you must enter the receive squelch frequency or code. Otherwise, leave this field empty.
- Sq Freq/Code (for TX Freq)
 - If you are testing transmitter CTCSS or CDCSS (test parameter 28 is set=1), you must enter the transmit squelch frequency or code. Otherwise, leave this field empty.
- **Test?** (yes/no) specifies whether you want to test the UUT at this channel. If set to "No" then the UUT will not be tested at that channel, but you may retain the channel information in the table for later use. If set to "Yes" then the channel will be used as defined by settings of **Prime?** and **All Chans?** fields.
- **Prime?** (yes/no) specifies which channels are "prime". Select "Yes" if you want to test the UUT at this channel on all the tests in the procedure. Select **No** if you want to test the UUT at this channel on just a subset of tests, which are designated by selecting **Yes** in the **All Chans** field of the **Order of Tests** screen. See **All Chans?** in "[Changing the Order of Tests](#)" on page 32 for more information.

For information on saving the channel information table, see "[Saving a Test Procedure](#)" on page 48.

The **All Chans** field in the **Order of Tests** screen interacts closely with the **Prime?** field on the **Channel Information** screen. When the software runs, it begins by retrieving the first channel entered into the **Channel Information** screen. It then checks the response in the **Test?** field to determine if the UUT should be tested at that channel at this time. If there is a **No** response in the **Test?** field, the software will go to the next channel in the table. If there is a **Yes** response in the **Test?** field, the software will check if the channel is **Prime**.

A **Yes** response in the **Prime?** field indicates to test the UUT at that channel on the entire sequence of tests in the procedure. A **No** response in the **Prime?** field indicates to test the UUT at that channel on a subset of tests in the procedure. The subset of tests is determined by a **Yes** response in the **All Chans?** field. Therefore, tests with a **No** response in the **All Chans?** field will be run on *prime* channels only.

Below is an example of how the software would run if you had a procedure set up as follows:

Table 1

Chan #	Test?	Prime?
Chan 01	Yes	Yes
Chan 02	Yes	No
Chan 03	No	No

Table 2

Test Number	All Chan? Setting
Test 01	No
Test 02	Yes
Test 03	Yes
Test 04	No

The result would be:

- Chan 01 is used in Test 01, Test 02, Test 03, and Test 04.
- Chan 02 is used in Test 02, and Test 03 only.
- Chan 03 is not used.

The following **table 3** shows how to properly configure these settings according to your testing needs.

Table 3

Testing Need	Necessary Field Settings		
	Test?	Prime?	All Chan?
Test channel on all tests in sequence	Yes	Yes	Don't Care
Test channel on a subset of tests in sequence	Yes	No	Yes on tests you want included in the testing subset
Do not test this channel now, but retain information for later use	No	Don't Care	Don't Care

How to Specify Channel Information

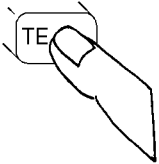
<p>1 Press TESTS to display the TESTS (Main Menu) screen.</p> <p><i>IF you are in IBASIC, press SHIFT, CANCEL before pressing TESTS.</i></p> 	<p>2 Position cursor and select Freq Channel Information.</p> <table border="1"> <tr> <td>Position</td> <td></td> <td>Freq Channel Information</td> </tr> <tr> <td>Select</td> <td></td> <td>Parm Test Parameters</td> </tr> <tr> <td></td> <td></td> <td>Seqn Order of Tests</td> </tr> <tr> <td></td> <td></td> <td>Spec Pass Fail Limits</td> </tr> <tr> <td></td> <td></td> <td>Proc Save/Delete Procedure</td> </tr> </table>	Position		Freq Channel Information	Select		Parm Test Parameters			Seqn Order of Tests			Spec Pass Fail Limits			Proc Save/Delete Procedure
Position		Freq Channel Information														
Select		Parm Test Parameters														
		Seqn Order of Tests														
		Spec Pass Fail Limits														
		Proc Save/Delete Procedure														
<p>The Channel Information screen is now present on your CRT.</p>	<p>3 Position cursor and select Chan # field.</p> <table border="1"> <tr> <td>Position</td> <td></td> <td>(Disregard this number.)</td> </tr> <tr> <td>Select</td> <td></td> <td>1</td> </tr> </table>	Position		(Disregard this number.)	Select		1									
Position		(Disregard this number.)														
Select		1														
<p>4 Scroll to and select desired Chan #.</p> <table border="1"> <tr> <td>Scroll</td> <td></td> <td>(This numbers are examples.)</td> </tr> <tr> <td>Select</td> <td></td> <td>6 0.00000000</td> </tr> </table>	Scroll		(This numbers are examples.)	Select		6 0.00000000	<p>5 Position cursor and select RX Freq (MHz) field.</p> <table border="1"> <tr> <td>Position</td> <td></td> <td>6 0.000000</td> </tr> <tr> <td>Select</td> <td></td> <td>0.000000</td> </tr> </table>	Position		6 0.000000	Select		0.000000			
Scroll		(This numbers are examples.)														
Select		6 0.00000000														
Position		6 0.000000														
Select		0.000000														

FREQ1

Continue on next page

6 Use **DATA** keys to enter new RX Freq, then select it.

Enter

Select

6 "New #"
(Enter your desired RX Freq)

7 Position cursor and select TX Freq (MHz) field.

Position

Select

0.000000
↑

8 Use **DATA** keys to enter new TX Freq, then select it.

Enter



Select

"New #"
(Enter your desired TX Freq)

If you are testing receiver/transmitter CTCSS or CDCSS do steps 9 - 12 to enter the receive/transmitt squelch frequency or codes, otherwise continue instructions at step 13.

9 Position cursor and select Sq Freq/Code field.

Position

Select

6 #.#####
↑

10 Use **DATA** keys to enter new Sq Freq/Code, then select it.



Enter

Select

6 #.#####
"New #"
(Enter your desired Sq Freq/Code)

Continue on next page

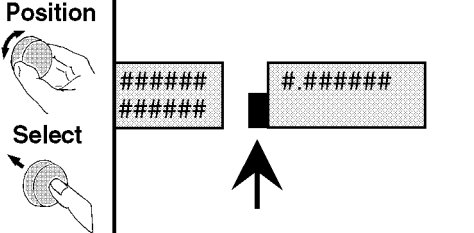
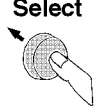
FREQ2

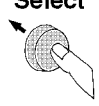
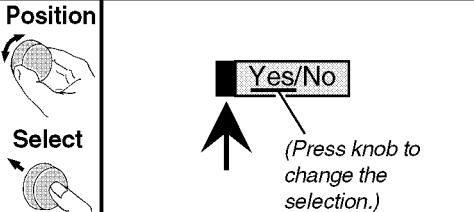
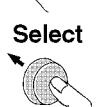
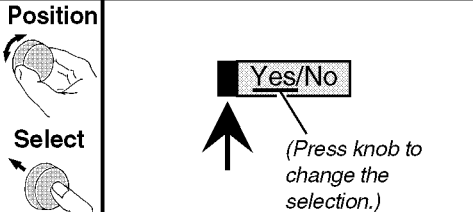
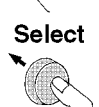
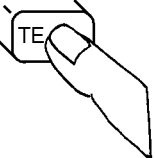
<p>11 Position cursor and select Sq Freq/Code field.</p>	<p>12 Use DATA keys to enter new Sq Freq/Code, then select it.</p>
<p>Position</p>  <p>Select</p> 	<p>Enter</p>  <p>Select</p>  <p>##### #.##### ##### "New #" (Enter your desired Sq Freq/Code.)</p>
<p>13 Position cursor at Test? field and select Yes or No.</p>	<p>14 Position cursor at Prime? field and select Yes or No.</p>
<p>Position</p>  <p>Select</p>  <p>Yes/No (Press knob to change the selection.)</p>	<p>Position</p>  <p>Select</p>  <p>Yes/No (Press knob to change the selection.)</p>
<p>15 Press TESTS to return to the TESTS (Main Menu) screen.</p>	
	







FREQ3

Changing Pass/Fail Limits

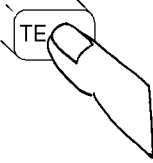
Pass/Fail limits define the values a measurement's result is compared against to determine if the UUT meets its specified standards. Default values are set in the test software. These default values may be changed to suit your particular requirements.





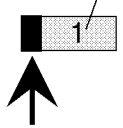











The following describes how to change the pass/fail (upper and lower) limits. See ["Pass/Fail Limit \(Specification\) Descriptions,"](#) in chapter 4, on page 145 for descriptions of each pass/fail limit. For information on saving customized pass/fail limits, see ["Saving a Test Procedure"](#) on page 48.

How to Change Pass/Fail Limits

<p>1 Press TESTS to display the TESTS screen.</p> <p><i>IF you are in IBASIC, press SHIFT, CANCEL before pressing TESTS.</i></p> 	<p>2 Position cursor and select Spec Pass Fail Limits.</p> <table border="1"> <tr> <td>Position</td> <td></td> </tr> <tr> <td></td> <td>Freq Channel Information</td> </tr> <tr> <td></td> <td>Parm Test Parameters</td> </tr> <tr> <td></td> <td>Seqn Order of Tests</td> </tr> <tr> <td>Select</td> <td>Spec Pass Fail Limits</td> </tr> <tr> <td></td> <td>Proc Save/Delete Procedure</td> </tr> </table>	Position			Freq Channel Information		Parm Test Parameters		Seqn Order of Tests	Select	Spec Pass Fail Limits		Proc Save/Delete Procedure
Position													
	Freq Channel Information												
	Parm Test Parameters												
	Seqn Order of Tests												
Select	Spec Pass Fail Limits												
	Proc Save/Delete Procedure												
<p>The Pass Fail Limits screen is now present on your CRT.</p>	<p>3 Position cursor and select Spec # field.</p> <p>(Disregard this number.)</p> 												



SPEC1

Continue on next page

<p>4 Scroll to and select desired Spec #.</p>	<p>5 Position cursor and select Lower limit field.</p>
<p>Scroll  Select </p> <p>(This Spec # is an example.)</p> <p>6 FCC TX output p -1.000000 1.</p> <p></p>	<p>Position  Select </p> <p>6 FCC TX output p -1.000000 1.</p> <p></p>
<p>6 Use DATA keys to enter new value, then select it.</p>	<p>7 Position cursor and select Upper Limit field.</p>
<p>Enter  Select </p> <p>6 FCC TX output p -0.500000 1.</p> <p>(Enter your desired value.)</p>	<p>Position  Select </p> <p>C TX output power adjustme .500000 1.000000 dB</p> <p></p>
<p>8 Use DATA keys to enter new value, then select it.</p>	<p>9 Position cursor and select Check field.</p>
<p>Enter  Select </p> <p>C TX output power adjustme .500000 0.500000 dB</p> <p>(Enter your desired value.)</p>	<p>Position  Select </p> <p>Both</p> <p></p>

SPEC2

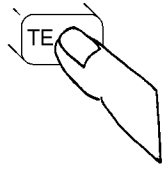
Continue on next page

10 <i>Position cursor and select Both .</i>		11 <i>Press TESTS to return to the TESTS (Main Menu) screen.</i>	
Position 		Choices : Upper Lower <input checked="" type="checkbox"/> Both None	
Select 			







SPEC3

Changing the Test Parameters

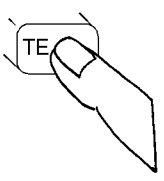
The software uses parameters to optimize the test environment and conditions for your testing situation. Many of the test parameters are determined by examining your test needs. The software comes with default settings for test parameters. Review the defaults for your particular needs. See "Test Parameter Descriptions," in chapter 4, on page 110 for descriptions of each test parameter. For information on saving customized test parameters, see "Saving a Test Procedure" on page 48.

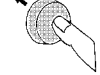

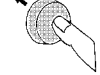

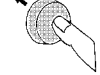







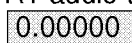



The following describes how you can change test parameters through the Test Parameter screen to optimize your testing conditions.

How to Change the Test Environment and Conditions

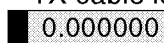
<p>1 Press TESTS to display the TESTS (Main Menu) screen.</p> <p><i>If you are in IBASIC, press SHIFT, CANCEL before pressing TESTS.</i></p> 	<p>2 Position cursor and select Parm Test Parameters.</p> <table border="1"><tr><td>Position</td><td></td></tr><tr><td></td><td></td></tr><tr><td>Select</td><td></td></tr><tr><td></td><td></td></tr></table> <table border="1"><tr><td>Freq</td><td>Channel Information</td></tr><tr><td>Parm</td><td>Test Parameters</td></tr><tr><td>Seqn</td><td>Order of Tests</td></tr><tr><td>Spec</td><td>Pass Fail Limits</td></tr><tr><td>Proc</td><td>Save/Delete Procedure</td></tr></table>	Position				Select				Freq	Channel Information	Parm	Test Parameters	Seqn	Order of Tests	Spec	Pass Fail Limits	Proc	Save/Delete Procedure
Position																			
																			
Select																			
																			
Freq	Channel Information																		
Parm	Test Parameters																		
Seqn	Order of Tests																		
Spec	Pass Fail Limits																		
Proc	Save/Delete Procedure																		

PARM1

Continue on next page

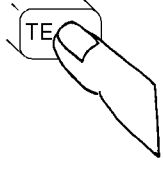
<p>The Tests Parameters screen is now present on your CRT.</p>	<p>3 Position cursor and select Parm # field.</p> <p>Position  Select </p> <p>(Entries on your display may be different.)</p> <p> RT audio test to </p> <p></p>
<p>4 Scroll to and select Parm # to be changed.</p> <p>Scroll  Select </p> <p>(This parameter number and description are examples.)</p> <p> TX cable loss </p>	<p>5 Position cursor and select Value field.</p> <p>Position  Select </p> <p> TX cable loss  </p>
<p>6 Use DATA keys to enter new value, then select it.</p> <p>Enter  Select </p> <p> TX cable loss   (Enter your desired value.)</p>	<p>7 Press TESTS to return to the TESTS (Main Menu) screen.</p> <p></p>

PAPM2

Saving a Test Procedure

A Test Procedure is a collection of channel information, test parameters, testing order, and pass/fail limits saved in a file that customizes the test software to a specific application. You may save the file to a memory card or disk. When you save a procedure you will be saving channel information, test parameters, pass/fail limits, and testing order, plus a library that contains the names of all test parameters, pass/fail limits, and tests that are resident in the software. The library file comes from the software and cannot be modified. The library file will be automatically saved on the card or disk that is being used to store the new test procedure.





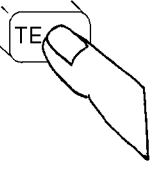
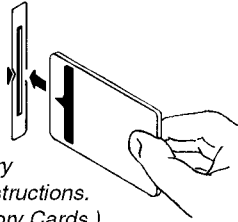

















The following example shows how to save a new procedure to a memory card. For more information concerning procedures, [see "Procedures," in chapter 5, on page 216.](#)

How to Save a Test Procedure

<p>1 Press TESTS to display the TESTS (Main Menu) screen.</p>	<p>2 Position cursor and select Proc Save/Delete Prodedure.</p>																
<p>If you are in IBASIC, press SHIFT, CANCEL before pressing TESTS.</p> 	<table border="1"> <tr> <td>Position</td> <td></td> <td></td> </tr> <tr> <td>Select</td> <td></td> <td> <table border="1"> <tr><td>Freq</td><td>Channel Information</td></tr> <tr><td>Parm</td><td>Test Parameters</td></tr> <tr><td>Seqn</td><td>Order of Tests</td></tr> <tr><td>Spec</td><td>Pass Fail Limits</td></tr> <tr><td>Proc</td><td>Save/Delete Procedure</td></tr> </table> </td> </tr> </table>	Position			Select		<table border="1"> <tr><td>Freq</td><td>Channel Information</td></tr> <tr><td>Parm</td><td>Test Parameters</td></tr> <tr><td>Seqn</td><td>Order of Tests</td></tr> <tr><td>Spec</td><td>Pass Fail Limits</td></tr> <tr><td>Proc</td><td>Save/Delete Procedure</td></tr> </table>	Freq	Channel Information	Parm	Test Parameters	Seqn	Order of Tests	Spec	Pass Fail Limits	Proc	Save/Delete Procedure
Position																	
Select		<table border="1"> <tr><td>Freq</td><td>Channel Information</td></tr> <tr><td>Parm</td><td>Test Parameters</td></tr> <tr><td>Seqn</td><td>Order of Tests</td></tr> <tr><td>Spec</td><td>Pass Fail Limits</td></tr> <tr><td>Proc</td><td>Save/Delete Procedure</td></tr> </table>	Freq	Channel Information	Parm	Test Parameters	Seqn	Order of Tests	Spec	Pass Fail Limits	Proc	Save/Delete Procedure					
Freq	Channel Information																
Parm	Test Parameters																
Seqn	Order of Tests																
Spec	Pass Fail Limits																
Proc	Save/Delete Procedure																
<p>The Save/Delete Procedure screen is now present on your CRT.</p>	<p>3 Position cursor and select Select Procedure Location.</p> <table border="1"> <tr> <td>Position</td> <td></td> <td>Select Procedure Location:</td> </tr> <tr> <td>Select</td> <td></td> <td></td> </tr> </table>	Position		Select Procedure Location:	Select												
Position		Select Procedure Location:															
Select																	
<p>4 Position cursor and select Card.</p>	<p>5 Insert an initialized SRAM memory card.</p>																
<table border="1"> <tr> <td>Position</td> <td></td> <td> <table border="1"> <tr><td>Choices :</td></tr> <tr><td>■ Card</td></tr> <tr><td>RAM</td></tr> <tr><td>Disk</td></tr> </table> </td> </tr> <tr> <td>Select</td> <td></td> <td> <p>(You can also save procedures to an internal RAM disk or external disk drive. See chapter 5 -Disks.)</p> </td> </tr> </table>	Position		<table border="1"> <tr><td>Choices :</td></tr> <tr><td>■ Card</td></tr> <tr><td>RAM</td></tr> <tr><td>Disk</td></tr> </table>	Choices :	■ Card	RAM	Disk	Select		<p>(You can also save procedures to an internal RAM disk or external disk drive. See chapter 5 -Disks.)</p>	 <p>(For detailed memory card initialization instructions. see chapter 5 -Memory Cards.)</p>						
Position		<table border="1"> <tr><td>Choices :</td></tr> <tr><td>■ Card</td></tr> <tr><td>RAM</td></tr> <tr><td>Disk</td></tr> </table>	Choices :	■ Card	RAM	Disk											
Choices :																	
■ Card																	
RAM																	
Disk																	
Select		<p>(You can also save procedures to an internal RAM disk or external disk drive. See chapter 5 -Disks.)</p>															





PROCMAN1

Continue on next page

<p>6 <i>Position cursor and select</i> Enter Procedure Filename:.</p> <p>Position  Select </p> <p>Enter Procedure Filename:  </p>	<p>7 <i>Select characters to name the procedure, then select Done.</i></p> <p>Position  Select </p> <p>  <table border="1" data-bbox="1058 541 1198 772"> <tr><td>Choices :</td></tr> <tr><td>Done</td></tr> <tr><td>Position</td></tr> <tr><td>Over/Ins</td></tr> <tr><td>Delete</td></tr> <tr><td>Del End</td></tr> <tr><td>Bk space</td></tr> <tr><td>A</td></tr> <tr><td>B</td></tr> <tr><td>C</td></tr> </table>  </p>	Choices :	Done	Position	Over/Ins	Delete	Del End	Bk space	A	B	C
Choices :											
Done											
Position											
Over/Ins											
Delete											
Del End											
Bk space											
A											
B											
C											
<p>8 <i>Position cursor and select</i> Enter Description for new</p> <p>Position  Select </p> <p>Enter Description for new  </p>	<p>9 <i>Select characters for the description, then select Done.</i></p> <p>Position  Select </p> <p>  <table border="1" data-bbox="1058 898 1208 1138"> <tr><td>Choices :</td></tr> <tr><td>Done</td></tr> <tr><td>Position</td></tr> <tr><td>Over/Ins</td></tr> <tr><td>Delete</td></tr> <tr><td>Del End</td></tr> <tr><td>Bk space</td></tr> <tr><td>A</td></tr> <tr><td>B</td></tr> <tr><td>C</td></tr> </table>  </p>	Choices :	Done	Position	Over/Ins	Delete	Del End	Bk space	A	B	C
Choices :											
Done											
Position											
Over/Ins											
Delete											
Del End											
Bk space											
A											
B											
C											
<p>10 <i>Position cursor at Procedure Library: and select Current.</i></p> <p>Position  Select </p> <p>Procedure Library:    <i>(The underline indicates which option is selected. Pressing knob changes the selection.)</i></p>	<p>11 <i>Position cursor and select Code Location:.</i></p> <p>Code Location:  </p>										

PROCMA12

Continue on next page

12 <i>Position cursor and select Card.</i>	13 <i>Position cursor and select Save Proc .</i>
<p>Position</p>  <p>Select</p> 	<p>Position</p>  <p>Select</p> 
<p>Choices :</p> <ul style="list-style-type: none">■ CardRAMDisk	<ul style="list-style-type: none">■ Save Proc2 Del Proc3 Init Card4 Help5 Main Menu

14 *Press TESTS to return to the TESTS (Main Tests) screen.*

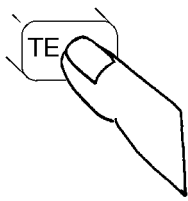

15 *To run the saved procedure, follow the instructions below.*

- 1) Insert the RAM card with your saved procedure.
- 2) On the **TESTS (Main Menu)** screen, A) position cursor and select **Select Procedure Location:**, then select **Card, B)** position cursor and select **Select Procedure Filename:**, then select your saved file name.)
- 3) Remove your RAM card and insert the original HP 11807A/E ROM memory card.
- 4) Press **Run Test** .

The original card contains the full program needed to run your procedure.

PROCMA85

Changing Test Execution Conditions

Test Execution Conditions define where and when test output occurs. You may decide to:

- Display output on CRT only, or display on CRT and print hardcopy (**Output Results To**).

NOTE:

If printing test results is desired, after selecting **Printer**, additional steps are necessary to connect and configure the printer. See "**Printing**," in chapter 5, on page 203.

- Display (or print) only measurements that fail, or display (or print) all measurements that pass or fail (**Output Results For**).
- Enter a title for an output heading for the displayed or printed results (**Output Heading**).
- Stop testing when a measurement fails or continue through all of the tests without stopping (**If Unit-Under-Test-Fails**).
- Pause between each measurement, or run through entire test (**Test Procedure Run Mode**).
- Start the program automatically when the Test System is powered on. (**Autostart Test Procedure on Power-up**)

Test Execution Conditions is accessed from the **SETUP TEST SET:** list. To change a default setting, position the cursor to the desired field. Pressing the knob ("selecting") will toggle the underlined selection.

Test Execution Conditions settings are not retained after a power-down/power-up cycle, and will return to their default settings.

How to Change Test Execution Conditions

1 Press **TESTS** to display the **TESTS (Main Menu)** screen.

If you are in IBASIC, press **SHIFT, CANCEL** before pressing **TESTS**.

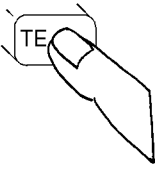

2 Position cursor at **Exec Execution Cond** and select it.

Position



Select



Exec	Execution Cond
Cnfg	External Devices
Print	Printer Setup
IBASIC	IBASIC Cntrl

3

Select **Printer** to output test procedure results to the CRT and a printer.

Select **Failures** to display only the CRT and printer measurements that fail.

Select **Stop** to stop a Test Procedure when a failure occurs.

Select **Single Step** to stop a Test Procedure at the end of each measurement.

TESTS (Execution Conditions)

Output Results To:	1 Run Test
Output Results For:	2 Continue
Output Heading:	4 Help
	5 Main Menu
To Screen RF GEN RF ANL RF ANL SCOPE SPEC ANL ENCODER DECODER RADIO INT More	
If Unit-Under-Test Fails:	
Test Procedure Run Mode:	
Autostart Test Procedure on Power-Up:	

TESTEXEa

Printing and Saving Test Results

Printing and saving test results are features of the software which require additional equipment and configuration. See ["Printing," in chapter 5, on page 203](#) for detailed descriptions and instructions for these features.

**Using the Software/HP 8920A FW Rev
Below A.14.00**

NOTE:

The firmware revision A.14.00 in the HP 8920A,D had several enhancements, which are standard in the HP 8920B. This chapter applies to users with:

- **HP 8920A test sets with firmware revision below A.14.00**

The test set's firmware revision is displayed on the top right corner of the configuration screen.

- Press SHIFT CONFIG to display the configuration screen and read the firmware revision.

If you have an HP 8920B or an HP 8920A with firmware revision above A.14.00, refer to [chapter 2, "Using the Software/HP 8920B, or HP 8920A FW Above Rev A.14.00," on page 21](#). Contact Hewlett-Packard at 1-800-922-8920 for details on upgrading your firmware if desired.

The HP 11807A software can be run on the factory default settings or customized to your individual needs and the specific requirements. This chapter provides detailed information on how to load, run, and customize the software.

Testing Overview

Pressing TESTS will display what is called the TESTS screen. To begin testing, you must first load the software and make connections. From this screen you have the option to:

Begin running tests:

- The factory default settings are acceptable for your application or
- The software has already been customized and saved to a memory card

Customize the software:

- Decide which tests you desire to run (**Edit Seqn**)
 - you may want to run all, some, or just one of the tests.
- Specify which channels to test (**Edit Freq**)
 - you may want to test one, some, or all of the channels on your radio.
- Change the pass/fail limits for specific measurements (**Edit Spec**)
 - you may want the pass/fail limits to have tighter or looser specifications than the default settings.
- Change the test environment and conditions (**Edit Parm**)
 - decide output format.
 - enter specific information about radio equipment and/or environment.
- Save any or all of the above customized changes to a memory card (**Proc Mngr**)

Set Up Test Set:

- Print test results or certain screens.
- Decide when and where test results are displayed (**Edit Cnfg**)

To Run Tests

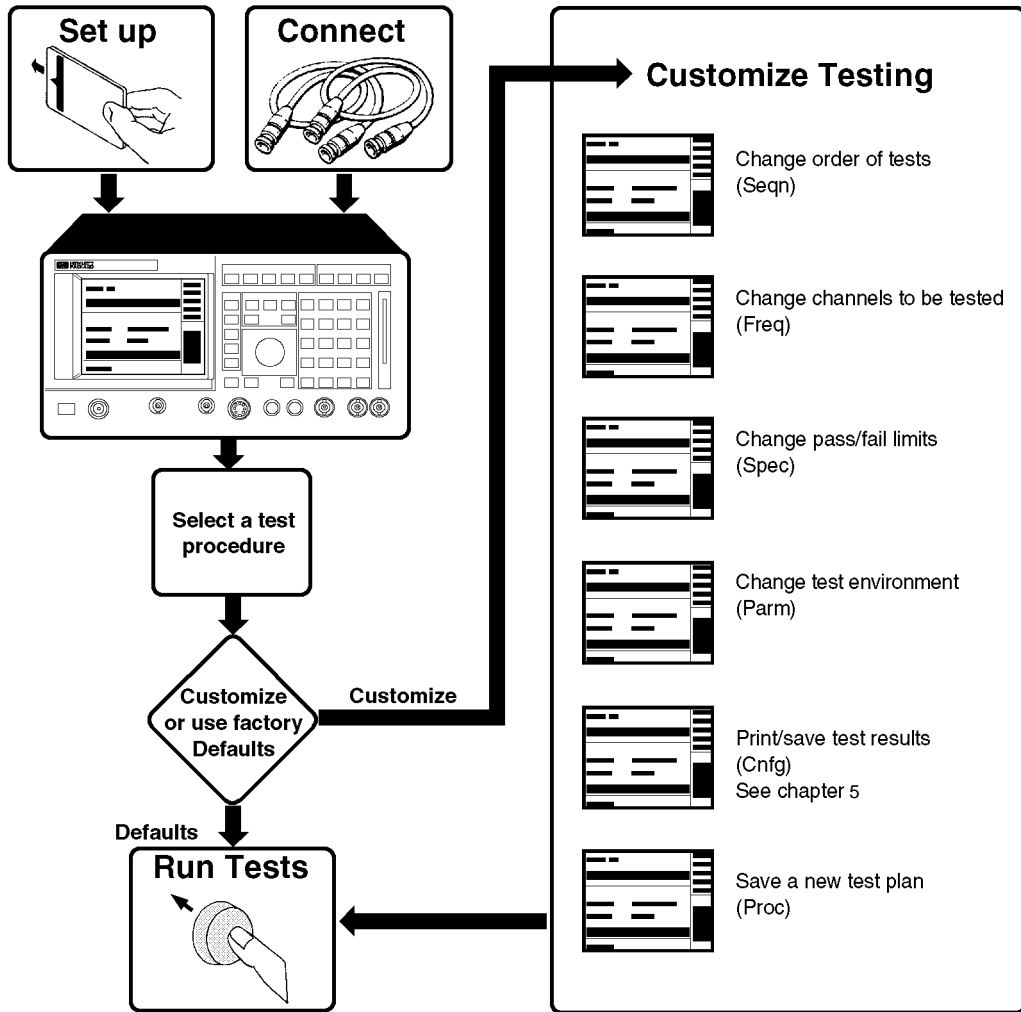

OVVIEWSB

Setting Up the Test Set and Making Connections

Before you begin testing, you must set up the test set and make the appropriate hardware connections.

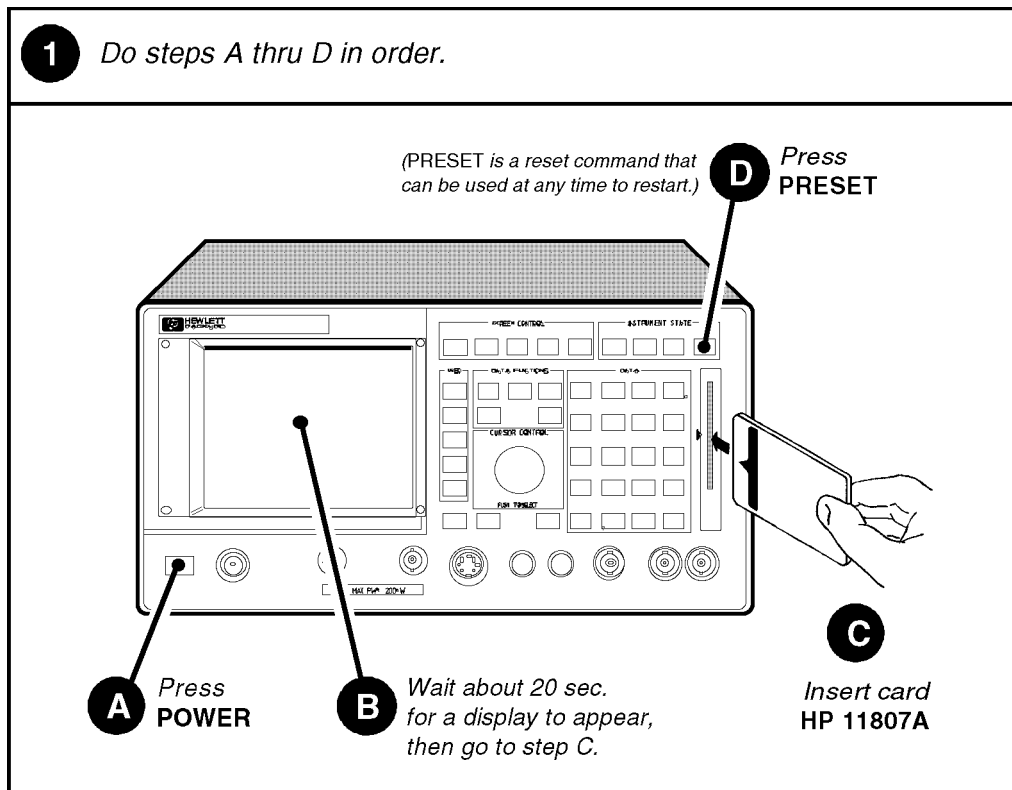

LOAD18

Making a Connection

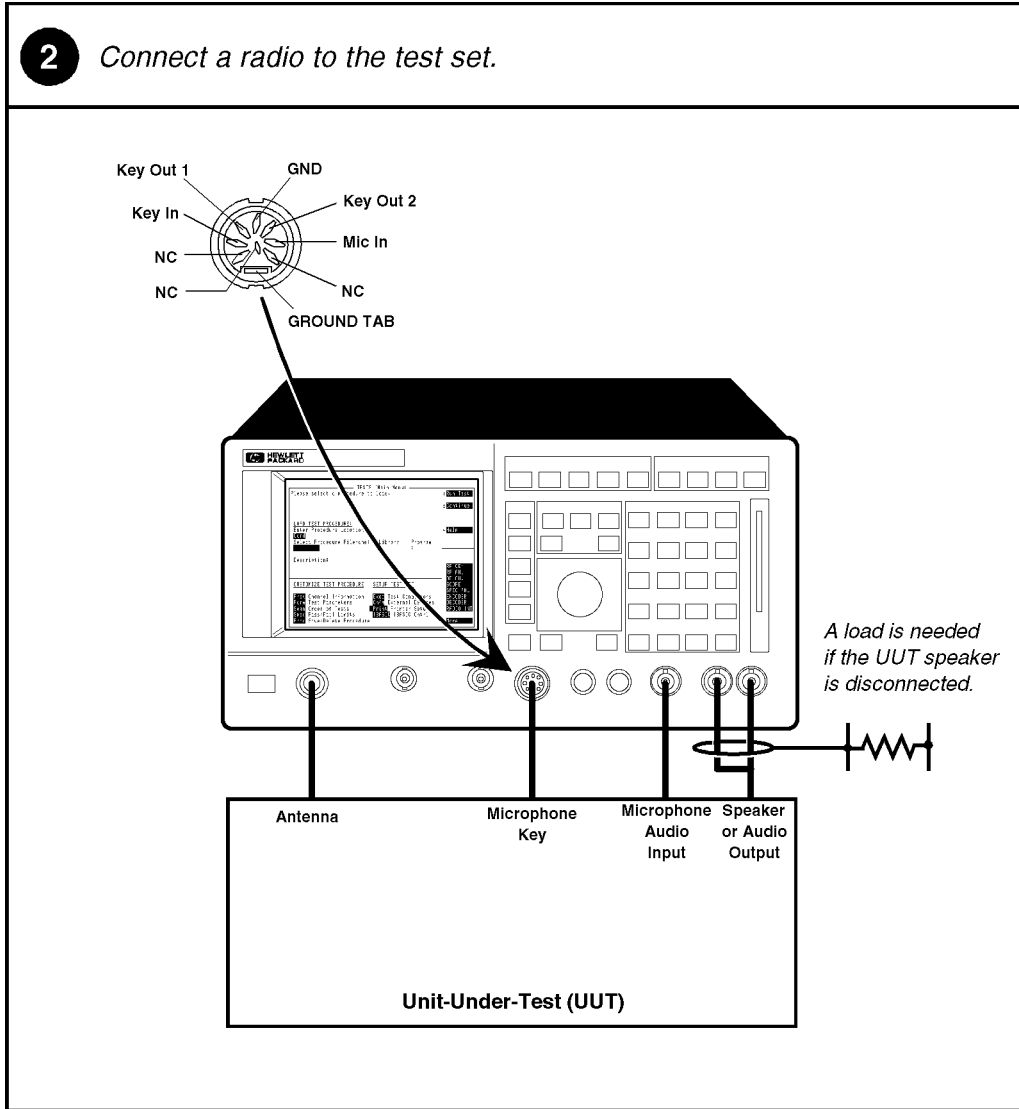

Selecting a Test Procedure









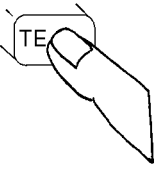

To load the software, you must first select the location to load from (in this case, it will be **Card**) and a procedure filename. Your card comes pre-programmed with at least one procedure. The actual software program does not get loaded into the test set's memory until k1 (**Run Test**) is selected. It will take approximately 2 minutes to load the software in an HP 8920A,D.

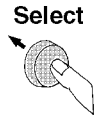
The software memory card can be removed after the program is loaded into the test set's memory. The program will remain in memory after a power-down/power-up cycle, unless it is manually deleted or a new program is loaded.

When tests begin to run, they are executed in the order in which they were entered into the Test Procedure.

Pressing CANCEL will pause the current test (press k2 to continue the test.)

Selecting A Test Procedure

<p>1 Press TESTS to display the TESTS screen.</p>	<p>2 Position cursor at Location and select it.</p>
<p>If you are in IBASIC, press SHIFT, CANCEL before pressing TESTS.</p> 	<p>Position</p>  <p>Procedure: Location</p> 
<p>3 Position cursor at Card and select it.</p>	<p>4 Position cursor at Procedure and select it.</p>
<p>Position</p>  <p>Select</p>  <p>Choices :</p> <ul style="list-style-type: none"> ■ Card ROM RAM Disk 	<p>Position</p>  <p>Select</p>  <p>Procedure: Location</p> <p>■ : Card</p>
<p>5 Position cursor at the desired Procedure and select it.</p>	<p>6 Position cursor at Run Test and select it.</p>
<p>Position</p>  <p>Select</p>  <p>Choices :</p> <ul style="list-style-type: none"> ■ XXXXXX YYYYYY ZZZZZZ 	<p>Position</p>  <p>Select</p>  <p>Procedures may take 2-3 minutes to load.</p> <ul style="list-style-type: none"> ■ Run Test 2 Continue 3 Edit Seqn 4 Edit Freq 5 Edit Spec

PROCED1B

Customizing Testing

Because of the diversity of individual testing needs, the software has been designed so that changes may be easily made from the test set's front panel. You may store these changes on an SRAM card so that you may skip these steps in the future. See ["Saving a Test Procedure Using the Procedure Manager" on page 82](#).

You may customize your software at any time. Because your needs change, the software allows changes to its default settings when you need to make them and in any order that you choose. For example, tests may be inserted or deleted, and later after running the tests you can change the pass/fail limits or decide to test different channels.

Most testing customization is accomplished through the test set's Test Function screens. These Test Function screens are accessed from the main TESTS screen as shown in the following figure. All Test Functions are explained in this chapter by function.

NOTE:

Edit Cnfg and IBASIC will not be explained in this customizing section.

- Edit Cnfg is used when setting up printers and external disk drives which is explained in ["Disks" in chapter 5, on page 189](#) and ["Printing" in chapter 5, on page 203](#).
- IBASIC is used when writing your own programs and is not explained in this manual. If you need to write your own IBASIC programs you may acquire the following manuals:
 - HP 8920A
 - *HP Instrument Basic User's Handbook* HP part number E2083-90000.
 - *HP 8920A Programming Manual* HP part number 08920-90220.
 - HP 8920B
 - *HP Instrument Basic User's Handbook Version 2.0* HP part number E2083-90005.
 - *HP 8920B Programming Manual* HP part number 08920-90222.

Beginning Software Customization

All software customization begins by accessing the TESTS screen first and then selecting the **Test Function** which will open the **Choices** menu. To access the TESTS screen, press TESTS on the front panel of the test set.

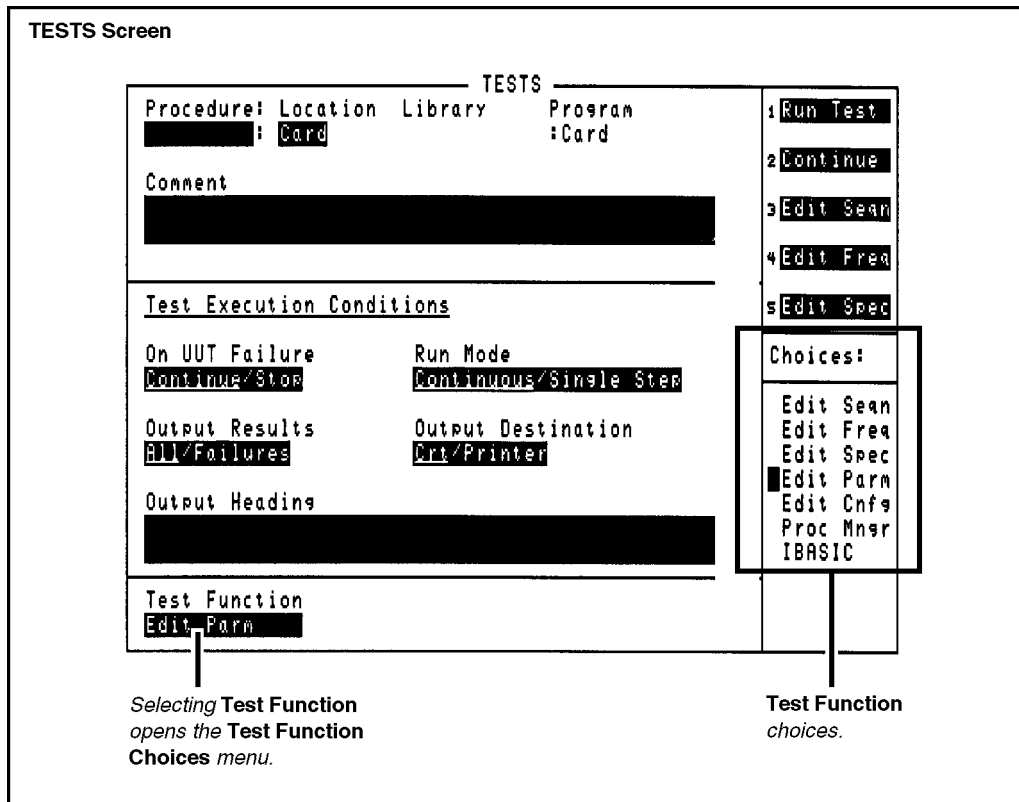

Changing the Order of Tests (Edit Sequence)







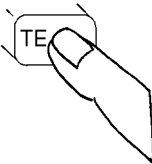

You may define a test sequence to include all, some, or just one of the tests available. When the first test is finished, the next will run. The test sequence will remain in the Test System's battery backed-up memory until another test sequence is loaded or set up. For information on saving a customized test sequence, see "[Saving a Test Procedure Using the Procedure Manager](#)" on page 82.

Creation of a test sequence is accomplished by inserting or deleting tests from the list of tests that come with the HP 11807A software package. See [chapter 4, "Test, Parameter, and Pass/Fail Limit \(Specification\) Descriptions,"](#) on page 89, for test descriptions.

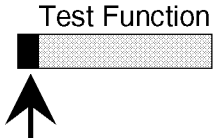
The **All Chans?** field allows the user to decide to run the test on all channels entered in the **Edit Frequency** table, or just the channels which are selected as **Prime** in the **Edit Frequency** screen. This feature allows the user the flexibility to use channels that are selected as **Prime** in all the tests in the sequence, and those indicated as non-prime in a subset of tests (those tests with a **Yes** response in **All Chans**). For more information, see "[Specifying Channel Information \(Edit Frequency\)](#)" on page 70.

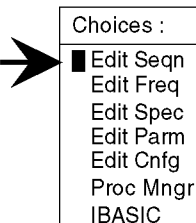

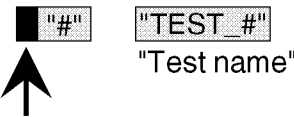

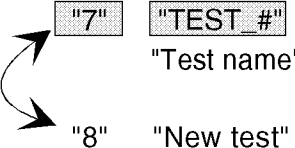







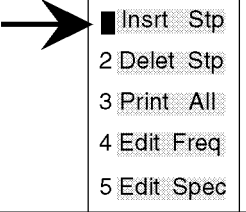

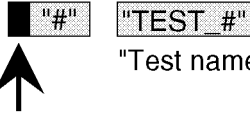
The following describes how to create a new test sequence and enter a response to **All Chans**.

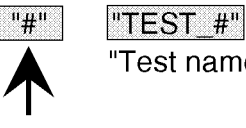
How to Change a Sequence of Tests

<p>1 Press TESTS to display the TESTS screen.</p>	<p>2 Position cursor at Test Function and select it.</p>
<p>If you are in IBASIC, press SHIFT, CANCEL before pressing TESTS.</p> 	<p>Position</p>  <p>Select</p>  
<p>3 Position cursor at Edit Seqn and select it.</p>	<p>4 Position cursor at Step # field and select it.</p>
<p>Position</p>  <p>Select</p>  	<p>Position</p>  <p>Select</p>  <p><i>Example</i></p> 
<p>5 By rotating knob, highlight the Step # which precedes the insertion point of the new test that you are adding, then select it.</p>	
<p>Rotate</p>  <p>Select</p> 	<p><i>For example, select step 7 if you want to insert the new test as step 8.</i></p> 

SEQ1B

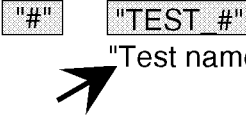
Continue on next page

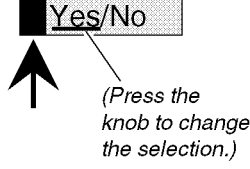
<p>6 Position cursor at Insrt Stp and select it.</p>	<p>7 Position cursor back at Step # field and select it.</p>
<p>Position</p>  <p>Select</p>  	<p>Position</p>  <p>Select</p>  
<p>8 Highlight Step # of the newly inserted test, then select it.</p>	<p>9 Position cursor at Test name field and select it.</p>
<p>Position</p>  <p>Select</p>  <p>This is the test that you selected at step 5.</p> 	<p>Position</p>  <p>Select</p>  
<p>10 Rotate knob until desired Test Name appears, then select it</p>	<p>11 Position cursor at All Chans? field and select Yes or No.</p>
<p>Rotate</p>  <p>Select</p>  	<p>Position</p>  <p>Select</p>  

5EQ2B

Continue on next page

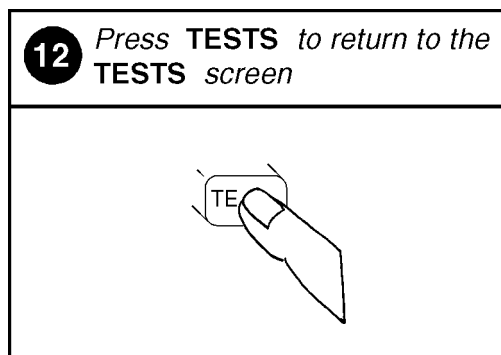

SEQ3B

Specifying Channel Information (Edit Frequency)

For each channel that you wish to specify, you must enter the following information into the **Edit Frequency** screen:

- RX Freq (MHz)
 - Enter the receive frequency of your radio in (MHz).
- TX Freq (MHz)
 - Enter the transmit frequency of your radio in (MHz).

NOTE: Enter a **-1** in the RX or TX test frequency fields to have all subsequent frequencies ignored when testing is started.

- RX Chan Info
 - If you are testing receiver CTCSS or CDCSS, you must enter the receive squelch frequency or code. Otherwise, leave this field empty.
- TX Chan Info
 - If you are testing transmitter CTCSS or CDCSS, you must enter the transmit squelch frequency or code. Otherwise, leave this field empty.
- **Test?** (yes/no) specifies whether you want to test the UUT at this channel. If set to “No” then the UUT will not be tested at that channel, but you may retain the channel information in the table for later use. If set to “Yes” then the channel will be used as defined by settings of **Prime?** and **All Chans?** fields.
- **Prime?** (yes/no) specifies which channels are “prime”. Select “Yes” if you want to test the UUT at this channel on all the tests in the procedure. Select **No** if you want to test the UUT at this channel on just a subset of tests, which are designated by selecting **Yes** in the **All Chans** field of the **Edit Sequence** screen. See **All Chans?** in "[Changing the Order of Tests \(Edit Sequence\)](#)" on page 66 for more information.

For information on saving the channel information table, see "[Saving a Test Procedure Using the Procedure Manager](#)" on page 82.

The **All Chans** field in the **Edit Sequence** screen interacts closely with the **Prime?** field on the **Edit Frequency** screen. When the software runs, it begins by retrieving the first channel entered into the **Edit Frequency** screen. It then checks the response in the **Test?** field to determine if the UUT should be tested at that channel at this time. If there is a **No** response in the **Test?** field, the software will go to the next channel in the table. If there is a **Yes** response in the **Test?** field, the software will check if the channel is **Prime**.

A **Yes** response in the **Prime?** field indicates to test the UUT at that channel on the entire sequence of tests in the procedure. A **No** response in the **Prime?** field indicates to test the UUT at that channel on a subset of tests in the procedure. The subset of tests is determined by a **Yes** response in the **All Chans?** field. Therefore, tests with a **No** response in the **All Chans?** field will be run on *prime* channels only.

Below is an example of how the software would run if you had a procedure set up as follows:

Table 4

Chan #	Test?	Prime?
Chan 01	Yes	Yes
Chan 02	Yes	No
Chan 03	No	No

Table 5

Test Number	All Chan? Setting
Test 01	No
Test 02	Yes
Test 03	Yes
Test 04	No

The result would be:









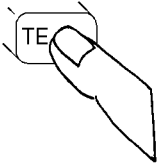

- Chan 01 is used in Test 01, Test 02, Test 03, and Test 04.
- Chan 02 is used in Test 02, and Test 03 only.
- Chan 03 is not used.

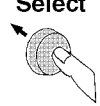
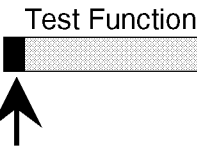
The following **table 6** shows how to properly configure these settings according to your testing needs.

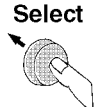
Table 6

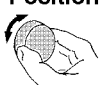
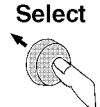
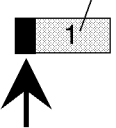

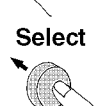
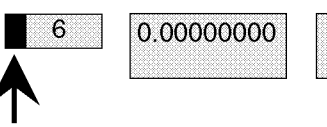

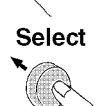
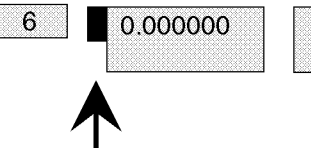







Testing Need	Necessary Field Settings		
	Test?	Prime?	All Chan?
Test channel on all tests in sequence	Yes	Yes	Don't Care
Test channel on a subset of tests in sequence	Yes	No	Yes on tests you want included in the testing subset
Do not test this channel now, but retain information for later use	No	Don't Care	Don't Care

How to Specify Channel Information

<p>1 Press TESTS to display the TESTS screen.</p> <p><i>IF you are in IBASIC, press SHIFT, CANCEL before pressing TESTS.</i></p> 	<p>2 Position cursor at Test Function and select it.</p> <p>Position</p>  <p>Select</p>  
<p>3 Position cursor at Edit Freq and select it.</p> <p>Position</p>  <p>Select</p>  	<p>4 Position cursor at Chan # field and select it.</p> <p>Position</p>  <p>Select</p>  <p><i>(Disregard this number.)</i></p> 
<p>5 Scroll to the desired Chan # and select it.</p> <p>Scroll</p>  <p>Select</p>  <p><i>(This Chan # is an example.)</i></p> 	<p>6 Position cursor and select RX Freq (MHz) field.</p> <p>Position</p>  <p>Select</p>  











FREQ1B

Continue on next page

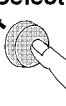
<p>7 Use DATA keys to enter new RX Freq, then select it.</p>	<p>8 Position cursor and select TX Freq (MHz) field.</p>
<p>Enter  Select </p> <p>6 "New #" (Enter your desired RX Freq.)</p>	<p>Position  Select </p> <p>##### 0.000000 </p>
<p>9 Use DATA keys to enter new TX Freq, then select it.</p>	<p>If you are testing receiver/transmitter CTCSS or CDCSS do steps 10 - 13 to enter the receive/transmitt squelch frequency or codes, otherwise continue instructions at step 14.</p>
<p>Enter  Select </p> <p>##### "New #" (Enter your desired TX Freq.)</p>	<p>10 Position cursor and select RX Chan Info field.</p>
<p>Position  Select </p> <p>6 #.##### </p>	<p>11 Use DATA keys to enter new Sq Freq/Code, then select it.</p> <p>Enter  Select </p> <p>6 #.##### "New #" (Enter your new info.)</p>

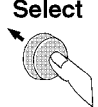
FREQ2B

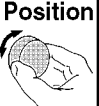
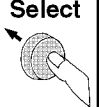
Continue on next page

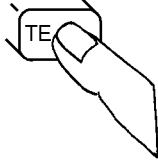
<p>12 Position cursor and select TX Chan Info field.</p>	<p>13 Use DATA keys to enter new Sq Freq/Code, then select it.</p>
<p>Position</p>  <p>Select</p>  <p>##### #.#####</p> 	<p>Enter</p>  <p>Select</p>  <p>##### #.##### ##### "New #"</p> <p>(Enter your New Info.)</p>
<p>14 Position cursor at Test? field and select Yes or No.</p>	<p>15 Position cursor at Prime? field and select Yes or No.</p>
<p>Position</p>  <p>Select</p>  <p>Yes/No</p>  <p>(Press knob to change the selection.)</p>	<p>Position</p>  <p>Select</p>  <p>Yes/No</p>  <p>(Press knob to change the selection.)</p>
<p>16 Press TESTS to return to the TESTS screen.</p>	
	







FREQ38

Changing Pass/Fail Limits (Edit Specifications)

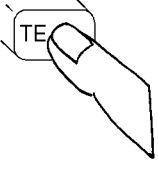

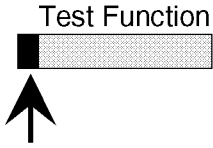



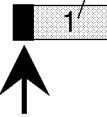









Specifications are values that set pass/fail limits for tests. Default values are available in the test software. These default values may be changed to suit your particular requirements.

The following describes how to change the pass/fail (upper and lower) limits in the HP 8920A,D **Edit Specification** screen. See "[Pass/Fail Limit \(Specification\) Descriptions](#)," in chapter 4, on page 145 for descriptions for each specification. For information on saving customized specifications, see "[Saving a Test Procedure Using the Procedure Manager](#)" on page 82.

How to Change Pass/Fail Limits





<p>1 Press TESTS to display the TESTS screen.</p>	<p>2 Position cursor at Test Function and select it.</p>
<p><i>IF you are in IBASIC, press SHIFT, CANCEL before pressing TESTS.</i></p> 	<p>Position</p>  <p>Select</p>  <p>Test Function</p> 
<p>3 Position cursor at Edit Spec and select it.</p>	<p>4 Position cursor at Spec # field and select it.</p>
<p>Position</p>  <p>Select</p>  <p>Choices :</p> <ul style="list-style-type: none"> Edit Seqn Edit Freq ■ Edit Spec Edit Parm Edit Cnfg Proc Mngr IBASIC 	<p>Position</p>  <p>Select</p>  <p>(Disregard this number.)</p> 

Continue on next page

<p>5 Scroll to the desired Spec # and select it.</p>	<p>6 Position cursor at Lower limit field and select it.</p>
<p>Position</p>  <p>(This Spec # is an example.)</p> <p>Select</p>  <p>6 FCC TX output p -1.000000 1.</p> 	<p>Position</p>  <p>6 FCC TX output p -1.000000 1.</p> <p>Select</p>  
<p>7 Use DATA keys to enter new value, then select it.</p>	<p>8 Position cursor at Upper Limit field and select it.</p>
<p>Position</p>  <p>6 FCC TX output p -0.500000 1.</p> <p>Select</p>  <p>(Enter your desired value.)</p>	<p>Position</p>  <p>C TX output power adjustme .500000 1.000000 dB</p> <p>Select</p>  
<p>9 Use DATA keys to enter new value, then select it.</p>	<p>10 Position cursor at Check field and select it.</p>
<p>Position</p>  <p>C TX output power adjustme .500000 0.500000 dB</p> <p>Select</p>  <p>(Enter your desired value.)</p>	<p>Position</p>  <p>Both</p> <p>Select</p>  

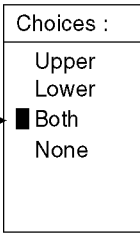
SPEC2B

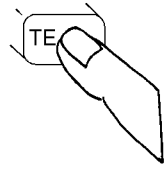
Continue on next page

11 <i>Position cursor at Both and select it.</i>	
Position 	 An arrow points from the left towards the 'Both' option in the menu.
Select 	
12 <i>Press TESTS to return to the TESTS screen.</i>	
Position 	
Select 	



SPEC3B

Changing the Test Environment and Conditions (Edit Parameters)

The software uses parameters to optimize the test environment and conditions for your testing situation. Many of the parameters are determined by examining your test needs. Other parameters are determined by performing measurements to calibrate items in your system. Examples of parameters include cable losses, rated system deviation, and the audio test tone frequency your system requires. The HP 11807A software comes with default settings for parameters. The defaults should be reviewed for your particular needs. See **"Test Parameter Descriptions," in chapter 4, on page 110** for descriptions and default values for each parameter. For information on saving customized parameters, see **"Saving a Test Procedure Using the Procedure Manager" on page 82**.



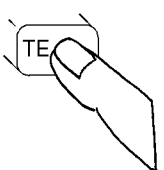

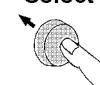
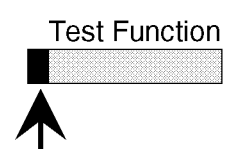





The following describes how you can change parameters through the Edit Parameter screen to optimize your testing conditions.

How to Change the Test Environment and Conditions

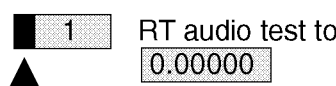
<p>1 Press TESTS to display the TESTS screen.</p>	<p>2 Position cursor at Test Function and select it.</p>
<p>If you are in IBASIC, press SHIFT, CANCEL before pressing TESTS.</p> 	<p>Position</p>  <p>Select</p>  <p>Test Function</p> 

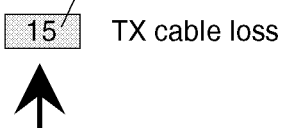
PARM1B

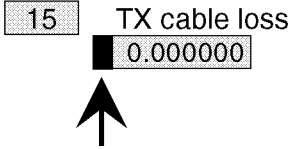
Continue on next page

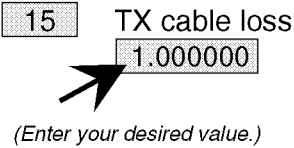
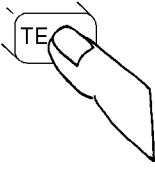
<p>3 Position cursor at Edit Parm and select it.</p>	<p>4 Position cursor at Parm # field and select it.</p>
<p>Position</p>  <p>Select</p>  	<p>(Entries on your display may be different.)</p> <p>Position</p>  <p>Select</p>  
<p>5 Scroll to Parm # to be changed and select it</p>	<p>6 Position cursor at Value field and select it.</p>
<p>Scroll</p>  <p>(This parameter number and description are examples.)</p> <p>Select</p>  	<p>Position</p>  <p>Select</p>  
<p>7 Use DATA keys to enter new value, and select it.</p>	<p>8 Press TESTS to return to the TESTS screen.</p>
<p>Enter</p>  <p>Select</p>   <p>(Enter your desired value.)</p>	











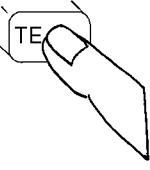

PARM2B

Saving a Test Procedure Using the Procedure Manager

A Test Procedure is a collection of pass/fail limits (specifications), the test environment and conditions (parameters), and a TEST sequence, saved in a file that customizes the test software to a specific application. You may save the file to a memory card or disk. When you save a Procedure you will be saving parameters, specifications, and a test sequence, plus a library that contains the names of all parameters, specifications, and tests that are resident in the HP 11807A software. The library file comes from the HP 11807A software and cannot be modified. The library file will be automatically saved on the card or disk that is being used to store the new test procedure.

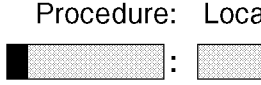
The following example shows how to save a new procedure to a memory card. For more information concerning procedures, [see "Procedures," in chapter 5, on page 216.](#)

How to Save a Test Procedure

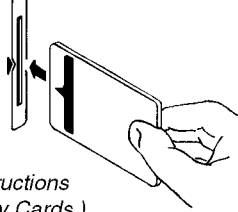
<p>1 Press TESTS to display the TESTS screen.</p>	<p>2 Position cursor at Test Function and select it.</p>
<p>If you are in IBASIC, press SHIFT, CANCEL before pressing TESTS.</p> 	<p>Position</p>  <p>Select</p>  
<p>3 Position cursor at Proc Mngr and select it.</p>	<p>4 Position cursor at Procedure field and select it.</p>
<p>Position</p>  <p>Select</p>  	<p>Position</p>  <p>Select</p>  
<p>5 Select characters to name the Procedure, then select Done.</p>	<p>6 Insert an initialized SRAM memory card.</p>
<p>Position</p>  <p>Select</p>  	 <p>(For detailed memory card initialization instructions see chapter 5 -Memory Cards.)</p>

PROCMA1B

Continue on next page

7 Position cursor at **Location** and select it.

Procedure: Location

8 Position cursor at **Card** and select it.

Position

Select

Choices :

- Card
- RAM
- Disk

(You can also save procedures to an internal RAM disk or external disk drive. See Chapter 5-Disks.)

9 Position cursor at **Comment** and select it.

Position

Select

Comment

10 Select characters for the **Comment**, then select **Done**.

Position

Select

Choices :

- Done
- Position
- Over/Ins
- Delete
- Del End
- Bk space
- A
- B
- C

11 Position cursor at **Library for new p....**, and select **Current**.

Position

Select

Library for new procedure

Current / [NO LIB]

(The underline indicates which option is selected. Pressing knob changes the selection.)

12 Position cursor at **Program location for** and select it.

Program location for new procedure

■ Card

Continue on next page

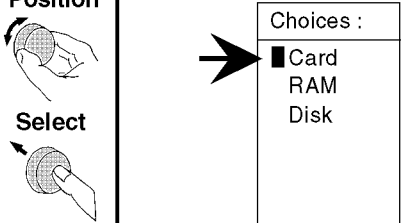
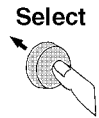
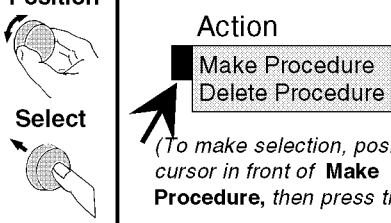
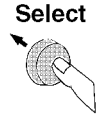
<p>13 Position cursor at Card and select it.</p>	<p>14 Position cursor at Action and select Make Procedure.</p>
<p>Position</p>  <p>Select</p> 	<p>Position</p>  <p>Select</p>  <p>Action</p> <p>Make Procedure Delete Procedure</p> <p>(To make selection, position the cursor in front of Make Procedure, then press the knob.)</p>
<p>15 Press TESTS to return to the TESTS screen.</p>	<p>To run the saved procedure:</p> <ol style="list-style-type: none">1) Load the Procedure.2) Insert the original HP 11807B memory card.3) Press Run Test. <p>The original card contains the full program needed to run your procedure.</p>

PROCMA3B

Changing Test Execution Conditions

Test Execution Conditions define how your testing program starts and where and when test output occurs. You may decide to:

- Start the program automatically when the Test System is powered on. (**Autostart**)
- Stop testing when a measurement fails or continue through all of the tests without stopping. (**On UUT Failure**)
- Display (or print) only measurements that fail, or display (or print) all measurements that pass or fail. (**Output Results**)
- Pause between each measurement, or run through the entire test sequence. (**Run Mode**)
- Display output on CRT only, or display on CRT and print hardcopy. (**Output Destination**)

NOTE:

If printing test results is desired, after selecting **Printer** additional steps are necessary to connect and configure the printer. See "**Printing**," in chapter 5, on page 203.

- Enter a title for an output heading for the displayed or printed results. (**Output Heading**). Select the field with the knob and enter the output heading by selecting the appropriate letters and the select **Done**.

Test Execution Conditions is located on the TESTS screen. Press TESTS to display them. To change a default setting, position the cursor to the desired field. Pressing the knob ("selecting") will toggle the underlined selection.

Test Execution Conditions settings (except for **Autostart**) are not retained after a power-down/ power-up cycle, and will return to their default settings. They are not stored on the memory card when a test procedure is saved.

How to Change Test Execution Conditions

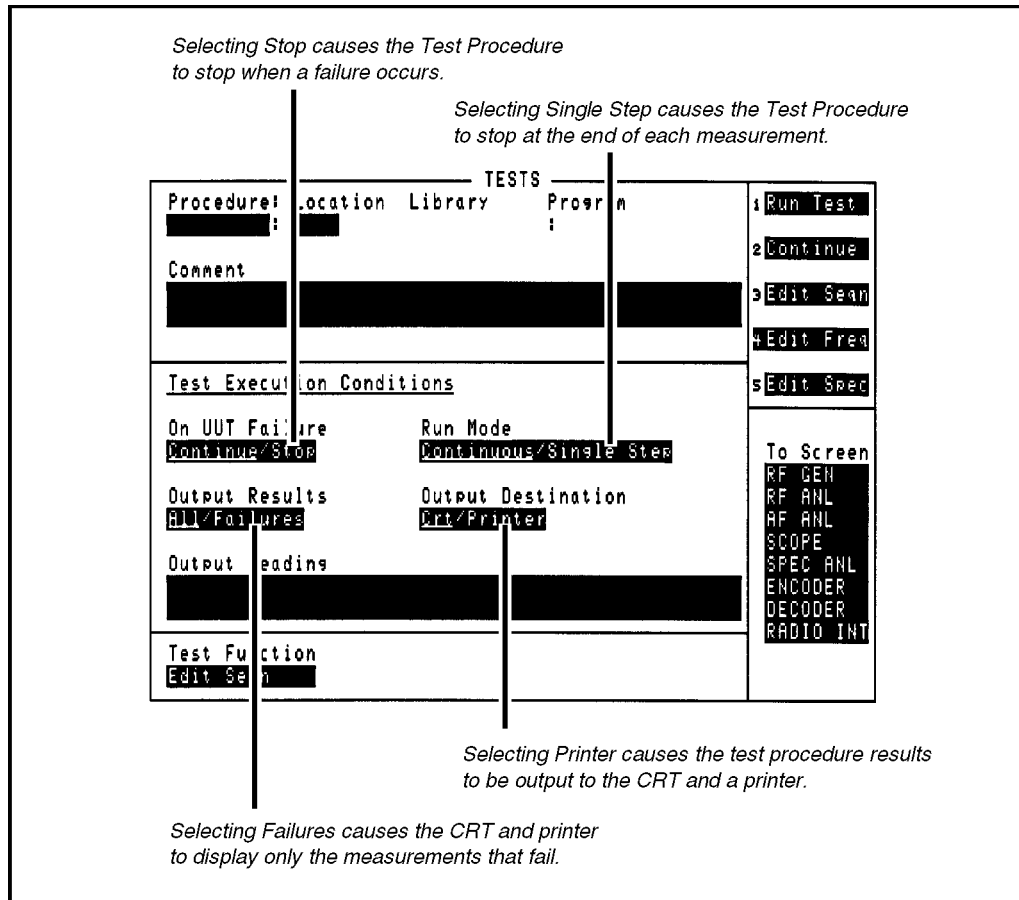

Printing and Saving Test Results

Printing and saving test results are features of the HP 11807A software which require additional equipment and configuration. See ["Printing," in chapter 5, on page 203](#) for detailed descriptions and instructions for these features.

Test, Parameter, and Pass/Fail Limit (Specification) Descriptions

Introduction

Tests are a series of measurements, and one or more tests make up a procedure (see [chapter 2, "Using the Software/HP 8920B, or HP 8920A FW Above Rev A.14.00," on page 21](#)). While you may change the tests that make up a procedure, you may not change the measurements the test will perform. Generally, the order in which the tests are run is not important.

This chapter describes each test and the associated test parameters, pass/fail limits, and external equipment that are required. When you first load a test procedure or create a new test sequence, refer to this section to understand what test parameters and pass/fail limits are required for each test.

Tests are derived from the following industry standards:

- Conference of European Postal Telecommunications (CEPT), Φ M Tests T/RA-24-01
- European Telecommunications Standards Institute (ETSI), Project Team 8 Final Report (June 1990)

NOTE:

Refer to [chapter 2](#) for details about customizing a Test Procedure for testing your FM radio.

TEST_01. TX and RX Stand-by Current Drain

This test measures the power-supply current required by the f M radio while it's in both the transmit and receive modes. While transmitting, current drain is measured without modulation, and while receiving, stand-by current drain is measured after the squelch control is set to maximum.

This test requires that the HP 8920A has the optional current-measuring circuit, Option 002, or that an external power supply is configured to the HP 8920A. If an external power supply is configured, this test reads current from the external supply.

NOTE:

The HP 11807A software does not zero the HP 8920A current-measuring circuit. Zeroing this circuit should be done periodically according to the instructions found in the HP 8920A *User's Guide*.

The transmitter and receiver stand-by current drain is measured in Amps.

Pass/fail Limits Used

Pass/Fail Limit 3. RX Audio Freq Resp Delta From 6 dB/oct
Pass/Fail Limit 17. TX Current Drain

TEST_02. TX Frequency Error

This test measures the difference between the unmodulated carrier frequency and the assigned carrier frequency. The frequency error is measured in kHz error.

Testing is performed at the nominal supply voltage and can also be performed with high and low-supply voltages for extreme measurements if a programmable power supply is configured to the HP 8920A. Refer to [chapter 1](#) for a list of programmable power supplies.

Pass/fail Limits Used

[Pass/Fail Limit 19. TX Frequency Error](#)

Test Parameters Used

[Parameter 6. RT High Supply Voltage](#)

[Parameter 7. RT Low Supply Voltage](#)

[Parameter 8. RT Nominal Supply Voltage](#)

[Parameter 9. RT Test At Extreme Settings](#)

TEST_03. TX Output Power Error

This test measures the power available at the output terminals of the transmitter when its connected to a 50 Ω load. Transmitter output error is measured in dB error and can be measured at the radio's low switch setting if desired.

Testing is performed at the nominal supply voltage and may be performed with high and low-supply voltages for extreme measurements if a programmable power supply is configured to the HP 8920A. Refer to [chapter 1](#) for a list of programmable power supplies.

Pass/fail Limits Used

- Pass/Fail Limit 22. TX Output Power Error
- Pass/Fail Limit 23. TX Output Power Error @ High Supply¹
- Pass/Fail Limit 24. TX Output Power Error @High Supply Lo SW¹
- Pass/Fail Limit 25. TX Output Power Error @Low Supply¹
- Pass/Fail Limit 26. TX Output Power Error @Low Supply Lo SW¹
- Pass/Fail Limit 27. TX Output Power Error Low Switch Setting²

Test Parameters Used

- Parameter 1. AS Rated Carrier Output Power
- Parameter 2. AS Rated Carrier Output Power Low Switch²
- Parameter 4. RT External Pad and Cable Loss
- Parameter 6. RT High Supply Voltage¹
- Parameter 7. RT Low Supply Voltage¹
- Parameter 8. RT Nominal Supply Voltage
- Parameter 9. RT Test At Extreme Settings
- Parameter 38. TX Output Power @Low Switch

1. These pass/fail limits and test parameters are used only when an external power supply is configured to the HP 8920A.
2. This pass/fail limit and parameter is used only if the power supply has a low switch setting.

TEST_04. TX Modulation Limiting

This test measures the ability of the transmitter circuits to prevent the transmitter from producing deviations in excess of the full-rated system deviation. The steady state peak+ and peak– frequency deviation is measured and reported.

Modulation limiting is measured in % of rated deviation. *Audio connections from the radio to the HP 8920A are required for this test.*

Testing is performed at the nominal supply voltage and can also be performed with high and low-supply voltages for extreme measurements if a programmable power supply is configured to the HP 8920A. Refer to [chapter 1](#) for a list of programmable power supplies.

If your radio has Continuous Digital-Controlled Squelch System (CDCSS), the added signal can cause this test to fail. In this case, disable the CDCSS circuitry.

Pass/fail Limits Used

[Pass/Fail Limit 21. TX Modulation Limiting](#)

Test Parameters Used

[Parameter 5. RT Full Rated System Deviation](#)

[Parameter 6. RT High Supply Voltage](#)

[Parameter 7. RT Low Supply Voltage](#)

[Parameter 8. RT Nominal Supply Voltage](#)

[Parameter 9. RT Test At Extreme Settings](#)

Testing Conditions Fixed by the Software

- Audio input level is increased 20 dB above the level required to produce 20% of rated system deviation.
- The steady state peak+ and peak– frequency deviation is measured at a 1 kHz rate.

TEST_05. TX Frequency Deviation

This test measures frequency deviation as the maximum difference in kHz between the instantaneous frequency of the modulated RF signal and the carrier signal in the absence of modulation. Full-rated system deviation is determined by **Parameter 5. RT Full Rated System Deviation**, while the modulation rate is swept over the desired audio band determined by test **Parameters 33-35. TX Freq Dev Start, Step, and Stop Freq For Audio Band**.

Audio connections from the radio to the HP 8920A are required for this test.

Pass/fail Limits Used

Pass/Fail Limit 18. TX Frequency Deviation

Test Parameters Used

Parameter 3. RT Channel Spacing

Parameter 5. RT Full Rated System Deviation

Parameters 33-35. TX Freq Dev Start, Step, and Stop Freq For Audio Band

Parameter 36. TX Freq Dev Tested >3 kHz

Testing Conditions Fixed by the Software

- Modulation limiting is measured at 20 dB above 60% of rated system deviation.
- Deviation is measured using the HP 8920A AF Analyzer's Pk+–Max detector.

TEST_06. TX Audio Frequency Response

This test measures the audio-frequency response of the transmitter with a constant input level maintained and the error in dB, relative to 1 kHz, is reported. Audio-frequency response is reported as a “modulation index error” (compared to [Pass/Fail Limit 14. TX Audio Modulation Index Error](#)) over a given frequency range (determined by test [Parameters 25-27. TX Audio Freq Response Start, Stop and Step Frequencies](#)).

Audio connections from the radio to the HP 8920A are required for this test.

Pass/fail Limits Used

[Pass/Fail Limit 14. TX Audio Modulation Index Error](#)

Test Parameters Used

[Parameter 5. RT Full Rated System Deviation](#)

[Parameters 25-27. TX Audio Freq Response Start, Stop and Step Frequencies](#)

Testing Conditions Fixed by the Software

- Audio-frequency response is measured at 20% of full-rated system deviation (set by [Parameter 5. RT Full Rated System Deviation](#)).
- A reference is taken at a 1 kHz rate.
- The HP 8920A AF Analyzer’s rms detector is used once the reference is set.

TEST_07. TX Audio Distortion

This test measures the audio-frequency harmonic distortion, which is the change in harmonic content of the input signal as it passes through the transmitter's audio and RF circuits. Transmitter audio distortion is measured in percent. *Audio connections from the radio to the HP 8920A are required for this test.*

Testing is performed at the nominal supply voltage and can also be performed with high and low-supply voltages for extreme measurements if a programmable power supply is configured to the HP 8920A. Refer to [chapter 1](#) for a list of programmable power supplies.

The 400 Hz High-Pass Filter is used by this test if Option 010 is installed in the HP 8920A.

If your radio has Continuous Digital-Controlled Squelch System (CDCSS), the added signal can cause this test to fail. In this case, disable the CDCSS circuitry.

Pass/fail Limits Used

[Pass/Fail Limit 13. TX Audio Distortion](#)

Test Parameters Used

[Parameter 5. RT Full Rated System Deviation](#)

[Parameter 6. RT High Supply Voltage](#)

[Parameter 7. RT Low Supply Voltage](#)

[Parameter 8. RT Nominal Supply Voltage](#)

[Parameter 9. RT Test At Extreme Settings](#)

[Parameter 31. TX De-emphasis](#)

Testing Conditions Fixed by the Software

- Audio distortion is measured at a 1 kHz rate.
- Measurements are carried out with a frequency deviation of 60% of full-rated system deviation (set by [Parameter 5. RT Full Rated System Deviation](#)). If testing is done at extreme power-supply voltages, measurements are carried out with a frequency deviation of 70% of full-rated system deviation.

TEST_08. TX Microphone Sensitivity

This test measures the frequency deviation at the microphone. Transmitter microphone sensitivity is measured in percent of full-rated system deviation.

Audio connections from the radio to the HP 8920A are required for this test.

Pass/fail Limits Used

[Pass/Fail Limit 20. TX Mic Sensitivity](#)

Test Parameters Used

[Parameter 5. RT Full Rated System Deviation](#)

[Parameter 37. TX Mic Sensitivity Level](#)

Testing Conditions Fixed by the Software

- The desired voltage (set by [Parameter 37. TX Mic Sensitivity Level](#)) is applied to the radio at a 1 kHz rate.
- The resulting frequency deviation at the microphone is measured using the HP 8920A AF Analyzer's Pk+—Max detector.

TEST_09. TX Residual Modulation

This test measures the transmitter's residual modulation as the ratio, expressed in dB of:

- the audio frequency noise power, produced after RF signal demodulation in the absence of modulation
 - by the wanted signal,
 - by the spurious effects of the radio's power supply,
 - by the modulator,
 - or by other causes,
- to the audio-frequency power produced by normal test modulation applied to the transmitter.

Audio connections from the radio to the HP 8920A are required for this test.

Pass/fail Limits Used

[Pass/Fail Limit 28. TX Residual Modulation](#)

Test Parameters Used

[Parameter 5. RT Full Rated System Deviation](#)

[Parameter 31. TX De-emphasis](#)

Testing Conditions Fixed by the Software

- Transmitter residual modulation is measured from a reference taken at 60% of full-rated system deviation (set by [Parameter 5. RT Full Rated System Deviation](#)).
- The HP 8920A AF Analyzer's rms detector is used once the reference is set.

TEST_10. TX CTCSS/CDCSS Deviation, Freq/Code

This test measures the peak+ deviation, and frequency error of the transmitted CTCSS (Continuous Tone-Controlled Squelch System) tones, or the transmitted CDCSS (Continuous Digital-Controlled Squelch System) code word.

Pass/fail Limits Used

Pass/Fail Limit 15. TX CT/CDCSS Deviation
Pass/Fail Limit 16. TX CTCSS Frequency Error

Parameter Used

Parameter 28. TX CT/CDCSS Available

TEST_11. RX Noise and Hum

This test measures the noise and hum of the receiver as the ratio, expressed in dB, of:

- the audio-frequency noise and hum power resulting from the spurious effects of the radio's power supply or from other causes,
- to the audio-frequency power produced by a high-level RF signal modulated by the full-rated system deviation applied to the receiver input.

Audio connections from the radio to the HP 8920A are required for this test.

Pass/fail Limits Used

[Pass/Fail Limit 6. RX Noise and Hum](#)

Test Parameters Used

[Parameter 5. RT Full Rated System Deviation](#)

[Parameter 18. RX Nominal Audio Power](#)

[Parameter 22. RX Tolerance For Setting Volume](#)

Testing Conditions Fixed by the Software

- The squelch control is set to minimum.
- The receiver's unquelled hum and noise is measured at 60% of full-rated system deviation (set by [Parameter 5. RT Full Rated System Deviation](#)), at a 1 kHz rate.
- The RF level is set to 30 dB μ V EMF.

TEST_12. RX Audio Distortion

This test measures audio distortion from the receiver when two RF signal levels (test **Parameters 12-13. RX Audio Distortion RF Level 1 and 2**) are applied to the radio. Distortion is the voltage ratio, expressed as a percentage, of:

- the rms value of the sum of the second and higher harmonic components,
- to the rms value of the complete signal at the output.

Testing is performed at the nominal supply voltage and can also be performed with high and low-supply voltages for extreme measurements and offset RF frequencies if a programmable power supply is configured to the HP 8920A. Refer to **chapter 1** for a list of programmable power supplies.

Audio connections from the radio to the HP 8920A are required for this test.

Pass/fail Limits Used

Pass/Fail Limit 2. RX Audio Distortion
Pass/Fail Limit 19. TX Frequency Error

Test Parameters Used

Parameter 5. RT Full Rated System Deviation
Parameter 6. RT High Supply Voltage
Parameter 7. RT Low Supply Voltage
Parameter 8. RT Nominal Supply Voltage
Parameter 9. RT Test At Extreme Settings
Parameters 12-13. RX Audio Distortion RF Level 1 and 2
Parameter 18. RX Nominal Audio Power
Parameter 22. RX Tolerance For Setting Volume

Testing Conditions Fixed by the Software

- The squelch control is set to minimum.
- The receiver's audio distortion is measured at two RF levels (set by test **Parameters 12-13. RX Audio Distortion RF Level 1 and 2**).
- The audio rate is set to 1 kHz.
- Audio distortion is measured at 60% of the full-rated system deviation (set by **Parameter 5. RT Full Rated System Deviation**).

TEST_13. RX Frequency Response

This test measures the audio-frequency response of the receiver which is expressed by variations in receiver audio-frequency output level, as a function of the modulated RF signal at the input. Audio-frequency response is measured in “dB error” from the 6 dB/octave pre-emphasis slope.

Audio connections from the radio to the HP 8920A are required for this test.

Pass/fail Limits Used

Pass/Fail Limit 3. RX Audio Freq Resp Delta From 6 dB/oct
Pass/Fail Limit 19. TX Frequency Error

Test Parameters Used

Parameter 3. RT Channel Spacing
Parameter 5. RT Full Rated System Deviation
Parameter 14. RX Audio Freq Response Step Frequency
Parameter 18. RX Nominal Audio Power
Parameter 22. RX Tolerance For Setting Volume

Testing Conditions Fixed by the Software

- The RF level is set to 60 dB μ V EMF and the audio power is adjusted to 50% of the rated audio-frequency power level.
- Audio-frequency response is measured 3 times, from 300 Hz to 3 kHz in steps determined by **Parameter 14. RX Audio Freq Response Step Frequency** and at different receiver (RX) frequencies set up in the **Channel Information (Edit Freq)** menu. (If channel spacing is set to 12.5 kHz by **Parameter 3. RT Channel Spacing**, the upper audio-frequency response range is limited to 2.55 kHz instead of 3 kHz.)
- A new reference is taken at each RF frequency at a 1 kHz rate.

TEST_14. RX Usable Sensitivity

This test measures the RF signal level required to produce the standard SINAD ratio (determined by [Parameter 24. RX Usable Sensitivity SINAD Level](#)) at the output of the receiver. *Audio connections from the radio to the HP 8920A are required for this test.* This test can be run in two different ways:

- The first method is the “iterative” test where [Parameter 23. RX Usable Sens Set And Meas](#) is set to “0”. In this case, usable sensitivity is measured at 60% of rated system deviation at a 1 kHz rate. The measured usable sensitivity is reported in the test results and compared to [Pass/Fail Limit 11. RX Usable Sensitivity](#) to determine if the test passed.
- The second method is the “set and measure” test where [Parameter 23. RX Usable Sens Set And Meas](#) is set to “1”. In this case, usable sensitivity is measured by setting the RF level to the upper limit of [Pass/Fail Limit 11. RX Usable Sensitivity](#) and SINAD is measured to determine if the test passed or failed.

Testing is performed at the nominal supply voltage and can also be performed with high and low-supply voltages for extreme measurements if a programmable power supply is configured to the HP 8920A. Refer to [chapter 1](#) for a list of supplies.

Pass/fail Limits Used

[Pass/Fail Limit 7. RX SINAD Audio Level Change at Extremes](#)

[Pass/Fail Limit 11. RX Usable Sensitivity](#)

[Pass/Fail Limit 12. RX Usable Sensitivity At Extremes](#)

Test Parameters Used

[Parameter 4. RT External Pad and Cable Loss](#)

[Parameter 6. RT High Supply Voltage](#)

[Parameter 7. RT Low Supply Voltage](#)

[Parameter 8. RT Nominal Supply Voltage](#)

[Parameter 9. RT Test At Extreme Settings](#)

[Parameter 18. RX Nominal Audio Power](#)

[Parameter 22. RX Tolerance For Setting Volume](#)

[Parameter 23. RX Usable Sens Set And Meas](#)

[Parameter 24. RX Usable Sensitivity SINAD Level](#)

TEST_15. RX Amplitude Characteristics

This test measures the amplitude characteristics of the receiver which is the relationship between the RF input level of a specified modulated signal and the audio-frequency level at the receiver output. *Audio connections from the radio to the HP 8920A are required for this test.*

Pass/fail Limits Used

[Pass/Fail Limit 1. RX Amplitude Characteristics Change](#)

Test Parameters Used

[Parameters 10-11. RX Amplitude Characteristic RF Level 1 and 2](#)

[Parameter 18. RX Nominal Audio Power](#)

[Parameter 22. RX Tolerance For Setting Volume](#)

Testing Conditions Fixed by the Software

- A normal test modulation is applied and volume is adjusted to 25% of the rated volume.
- The RF level is then set to two different levels, the audio output is measured, and the difference calculated.

TEST_16. RX Audio Squelch Sensitivity

This test measures the minimum signal level required from a standard input signal, which, when modulated at standard test modulation, will open the receiver squelch.

Both “threshold” and “tight squelch” sensitivity are measured in this test. Threshold sensitivity is measured with the squelch adjusted for ≥ 40 dB noise quieting. Tight squelch sensitivity is measured with the squelch adjusted to the tight (maximum) test position.

Audio connections from the radio to the HP 8920A are required for this test. Threshold and tight squelch sensitivity are both measured in dB μ V EMF.

Pass/fail Limits Used

[Pass/Fail Limit 9. RX Threshold Squelch Sensitivity](#)

[Pass/Fail Limit 10. RX Tight Squelch Sensitivity](#)

Test Parameters Used

[Parameter 4. RT External Pad and Cable Loss](#)

[Parameter 18. RX Nominal Audio Power](#)

[Parameter 21. RX Squelch Preset Only](#)

[Parameter 22. RX Tolerance For Setting Volume](#)

Testing Conditions Fixed by the Software

- If [Parameter 21. RX Squelch Preset Only](#) is set to indicate that the radio only has a preset squelch, the section of the test measuring “tight squelch” sensitivity is skipped.
- During testing, volume is adjusted to be at 60% rated system deviation at a 1 kHz rate.

TEST_17. RX CTCSS/CDCSS Opening

This test measures the level of the RF signal (with the squelch tone) required to open the squelch circuit of the radio with a CTCSS (Continuous Tone-Controlled Squelch System) tone applied, or a CDCSS (Continuous Digital-Controlled Squelch System) code word applied. The SINAD at the measured opening level is also measured.

Audio connections from the radio to the HP 8920A are required for this test.

Pass/fail Limits Used

Pass/Fail Limit 4. RX CT/CDCSS Opening Level
Pass/Fail Limit 5. RX CT/CDCSS SINAD At Opening

Test Parameters Used

Parameter 4. RT External Pad and Cable Loss
Parameter 16. RX CT/CDCSS Available/Control
Parameter 17. RX CT/CDCSS Deviation
Parameter 18. RX Nominal Audio Power
Parameter 22. RX Tolerance For Setting Volume

TEST_18. RX Quick Test

This test contains a subset of the complete test list for receivers. It is designed to do a quick evaluation of the receiver using the following tests:

- **TEST_11. RX Noise and Hum**
- **TEST_12. RX Audio Distortion**
- **TEST_13. RX Frequency Response**
- **TEST_14. RX Usable Sensitivity**
- **TEST_15. RX Amplitude Characteristics**

Pass/fail Limits Used

Refer to each test shown above for the pass/fail limits that are used.

Test Parameters Used

Refer to each test shown above for the test parameters that are used.

TEST_19. TX Quick Test

This test contains a subset of the complete test list for transmitters. It is designed to enable you to do a quick evaluation of the transmitter using the following tests:

- [TEST_02. TX Frequency Error](#)
- [TEST_03. TX Output Power Error](#)
- [TEST_06. TX Audio Frequency Response](#)
- [TEST_04. TX Modulation Limiting](#)
- [TEST_07. TX Audio Distortion](#)
- [TEST_05. TX Frequency Deviation](#)
- [TEST_09. TX Residual Modulation](#)
- [TEST_08. TX Microphone Sensitivity](#)

Pass/fail Limits Used

Refer to each test shown above for the pass/fail limits that are used.

Test Parameters Used

Refer to each test shown above for the test parameters that are used.

Test Parameter Descriptions

Test parameters are used to define the conditions under which a test will run. You may edit the test parameters to change the default values to meet your specific testing needs and conditions. Test parameters may be used in one or more tests.

For information on editing test parameters, see ["Customizing Testing," in chapter 2, on page 30.](#)

Test parameters remain in battery-backed-up memory until you select a procedure to run. If you wish to prevent them from being lost when a new procedure is selected, you will have to save them in a procedure. See ["Saving a Test Procedure," in chapter 2, on page 48.](#)

To print the list of test parameters, see ["To print TESTS screens;," in chapter 5, on page 210.](#)

There are several different types of test parameters:

- Receiver/Transmitter Test Parameters (RT)
- Receiver Test Parameters (RX)
- Transmitter Test Parameters (TX)
- Extra Test Parameters (XX)

NOTE: Refer to [chapter 2](#) for details about selecting test parameters for your FM radio.

Parameter 1. AS Rated Carrier Output Power

This test parameter refers to the transmitter's rated output power as declared by the manufacturer and is used as a basis for calculating the pass/fail limits when the radio is tested for output-power error.

For Example:

If the transmitter's output power is rated at 8.5 Watts, you would enter **8.5** in the value column. This value must be entered in Watts.

It's Used In The Following Tests:

[TEST_03. TX Output Power Error](#)

[TEST_19. TX Quick Test](#)

Parameter 2. AS Rated Carrier Output Power Low Switch

This test parameter refers to the transmitter's rated output power as declared by the manufacturer and is used as a basis for calculating the pass/fail limits when the radio is tested for output-power error at its low-switch setting.

For Example:

If the transmitter's output power at its low-switch setting is rated at 5 Watts, you would enter 5 in the value column. This value must be entered in Watts.

It's Used In The Following Tests:

[TEST_03. TX Output Power Error](#)

[TEST_19. TX Quick Test](#)

Parameter 3. RT Channel Spacing

This test parameter allows you to set the radio's channel spacing (that is, channel separation) to be recognized by the software for testing frequency deviation and response.

For Example:

If your radio has a channel spacing of 25 kHz, you would enter **25** in the value column. This value must be entered in kHz.

It's Used In The Following Tests:

- TEST_05. TX Frequency Deviation**
- TEST_13. RX Frequency Response**
- TEST_18. RX Quick Test**
- TEST_19. TX Quick Test**

Parameter 4. RT External Pad and Cable Loss

This test parameter allows you to set the amount of loss for any external cables or pads (attenuators) that are connected to the Test Set.

Besides being used in the tests shown below, pad and cable loss is compensated for in power measurements and in signal generator level settings by subroutines in the software whenever:

- finding the radio's squelch sensitivity.
- setting the Test Set RF level to the desired level in dBm.

For Example:

If a 30 dB attenuator is connected in line with the radio's antenna, you would enter 30 in the value column. This value must be entered in dB.

It's Used In The Following Tests:

- [TEST_03. TX Output Power Error](#)
- [TEST_14. RX Usable Sensitivity](#)
- [TEST_16. RX Audio Squelch Sensitivity](#)
- [TEST_17. RX CTCSS/CDCSS Opening](#)
- [TEST_18. RX Quick Test](#)
- [TEST_19. TX Quick Test](#)

Parameter 5. RT Full Rated System Deviation

This test parameter sets the full-rated (maximum) deviation used by the Test Set during receiver and transmitter tests.

Besides being used in the tests shown below, full-rated system deviation is set on the Test Set by subroutines in the software whenever:

- the Test Set is set to the standard receiver mode.
- transmitter deviation is set on the Test Set.

For Example:

If your industry standard specifies the full-rated system deviation to be 5 kHz, you would enter 5 in the value column. This value must be entered in kHz.

It's Used In The Following Tests:

- TEST_04. TX Modulation Limiting
- TEST_05. TX Frequency Deviation
- TEST_06. TX Audio Frequency Response
- TEST_07. TX Audio Distortion
- TEST_08. TX Microphone Sensitivity
- TEST_09. TX Residual Modulation
- TEST_11. RX Noise and Hum
- TEST_12. RX Audio Distortion
- TEST_13. RX Frequency Response
- TEST_18. RX Quick Test
- TEST_19. TX Quick Test

Parameter 6. RT High Supply Voltage

This test parameter sets the high-power setting on the radio's external power supply (if one is used) when testing under extreme voltage conditions.

For Example:

If your industry standard specifies the high-supply voltage required for extreme measurements as +20% of the normal (nominal) supply voltage, which is +13.2V for the radio's power supply, you would enter **15.8** in the value column. This value must be entered in Vdc.

It's Used In The Following Tests:

- TEST_02. TX Frequency Error
- TEST_03. TX Output Power Error
- TEST_04. TX Modulation Limiting
- TEST_07. TX Audio Distortion
- TEST_12. RX Audio Distortion
- TEST_14. RX Usable Sensitivity
- TEST_18. RX Quick Test
- TEST_19. TX Quick Test

NOTE: The power supply must be set up in the **External Devices** (or **Edit Cnfg**) screen. Refer to the *HP 8920A User's Guide* for information about configuring a power supply.

Parameter 7. RT Low Supply Voltage

This test parameter sets the low-power setting on the radio's external power supply (if one is used) when testing under extreme voltage conditions.

For Example:

If your industry standard specifies the low-supply voltage required for extreme measurements as -20% of the normal (nominal) supply voltage, which is +13.2V for the radio's power supply, you would enter **10.6** in the value column. The value is entered in Vdc.

It's Used In The Following Tests:

- TEST_02. TX Frequency Error**
- TEST_03. TX Output Power Error**
- TEST_04. TX Modulation Limiting**
- TEST_07. TX Audio Distortion**
- TEST_12. RX Audio Distortion**
- TEST_14. RX Usable Sensitivity**
- TEST_18. RX Quick Test**
- TEST_19. TX Quick Test**

NOTE: The power supply must be set up in the **External Devices** (or **Edit Cnfg**) screen. Refer to the *HP 8920A User's Guide* for information about configuring a power supply.

Parameter 8. RT Nominal Supply Voltage

This test parameter sets the nominal (that is, normal) power-supply voltage required by the radio. Besides being used in the tests shown below, this test parameter is used whenever the Test Set is initialized prior to starting a Test Procedure.

For Example:

If your radio specification lists the nominal supply voltage to be +13.8V, you would enter **13.8** in the value column. This value must be entered in Vdc.

It's Used In The Following Tests:

- TEST_02. TX Frequency Error**
- TEST_03. TX Output Power Error**
- TEST_04. TX Modulation Limiting**
- TEST_07. TX Audio Distortion**
- TEST_12. RX Audio Distortion**
- TEST_14. RX Usable Sensitivity**
- TEST_18. RX Quick Test**
- TEST_19. TX Quick Test**

NOTE:

The power supply must be set up in the **External Devices** (or **Edit Cnfg**). Refer to the *HP 8920A User's Guide* for information about configuring a power supply.

Parameter 9. RT Test At Extreme Settings

This test parameter allows measurements to be made at extreme high and low-power voltage settings (determined by test [Parameter 6. RT High Supply Voltage](#) and [Parameter 7. RT Low Supply Voltage](#)). This test parameter works only when HP-IB control of the power supply is used.

For Example:

When this test parameter is set to **1** (yes), the tests shown below will run at both high and low-power voltage settings. When this test parameter is set to **0** (no), the tests shown below will run at the nominal-supply voltage setting only.

It's Used In The Following Tests:

- [TEST_02. TX Frequency Error](#)
- [TEST_03. TX Output Power Error](#)
- [TEST_04. TX Modulation Limiting](#)
- [TEST_07. TX Audio Distortion](#)
- [TEST_12. RX Audio Distortion](#)
- [TEST_14. RX Usable Sensitivity](#)
- [TEST_18. RX Quick Test](#)
- [TEST_19. TX Quick Test](#)

NOTE: The power supply must be set up in the **External Devices** (or **Edit Cnfg**). Refer to the *HP 8920A User's Guide* for information about configuring a power supply.

Parameters 10-11. RX Amplitude Characteristic RF Level 1 and 2

These test parameters set the RF level of the nominal receiver frequency that is applied to the receiver's input for testing amplitude characteristics. RF Level 1 is the first RF level setting that is used when the audio output is measured, RF Level 2 is used to set the second RF level. The difference in measured audio-output levels is then calculated and compared to [Pass/Fail Limit 1. RX Amplitude Characteristics Change](#) to see if the test passed.

For Example:

If your industry standard sets the first RF level of the test signal that is used to test the amplitude characteristics of the receiver at +6 dB μ V EMF, you would enter **6** in the value column. Then, if your industry standard sets the second RF level at +100 dB μ V EMF, you would enter **100** in the value column. These values must be entered in dB μ V EMF.

It's Used In the Following Tests:

[TEST_15. RX Amplitude Characteristics](#)

[TEST_18. RX Quick Test](#)

Parameters 12-13. RX Audio Distortion RF Level 1 and 2

These test parameters set the RF level for the test signals that are used to measure the receiver's audio (harmonic) distortion. The difference in measured audio-distortion levels is then calculated and compared to [Pass/Fail Limit 2. RX Audio Distortion](#) to see if the test passed.

For Example:

If your industry standard recommends using test signals of 60 and 100 dB μ V EMF, you would enter **60** and **100** in the value columns. These values must be entered in dB μ V EMF.

It's Used In The Following Tests:

[TEST_12. RX Audio Distortion](#)
[TEST_18. RX Quick Test](#)

Parameter 14. RX Audio Freq Response Step Frequency

This test parameter sets the step size used to vary the modulation frequency used in testing the receiver's frequency response. The modulation frequency is fixed by the software to start at 300 Hz and to end at 3 kHz.

For Example:

If you want the modulation frequency for testing audio-frequency response to be varied in steps of 500 Hz, you would enter 0.5 in the value column. The value must be entered in kHz.

It's Used In The Following Tests:

[TEST_13. RX Frequency Response](#)

[TEST_18. RX Quick Test](#)

Parameter 15. RX Audio Load Impedance

This test parameter allows you to enter the output impedance of the receiver circuitry. The value you set for this test parameter is used by the software to determine how radio volume and squelch will be adjusted during testing.

A load resistor of the same value set with this test parameter must be integrated into the radio or its interface to the Test Set AUDIO IN connector for accurate power settings and test measurements.

For Example:

If your radio specification sets audio-output power into an 8 Ω load, you would enter **8** in the value column. The value must be entered in ohms.

It's Used In The Following Tests:

ALL TESTS. Whenever volume and/or squelch is adjusted.

Parameter 16. RX CT/CDCSS Available/Control

This test parameter lets the Test Set know whether the receiver's audio-squelch circuitry uses Continuous-Tone-Controlled Squelch System (CTCSS) or uses Continuous Digital-Controlled Squelch System (CDCSS), and whether either CTCSS or CDCSS can be controlled to be turned on and off during testing.

For Example:

Enter a **0** in the value column to indicate that the radio does not use CTCSS or CDCSS.

Enter a **1** in the value column to indicate that the radio has CTCSS or CDCSS and that the operator can disable and enable the squelch tone or code word during receiver testing.

It's Used In The Following Tests:

TEST_17. RX CTCSS/CDCSS Opening

A subroutine in the software also uses this test parameter whenever the receiver or transmitter tone-squelch circuit is turned on or off.

Parameter 17. RX CT/CDCSS Deviation

This test parameter sets the amount of deviation on the signal modulating the CTCSS tone which is input to the receiver's antenna during the CTCSS opening test. With CDCSS, the code word produces the necessary deviation.

For Example:

If you want the CTCSS tone to deviate 750 Hz during the CTCSS opening test, you would enter **0.75** in the value column. The value is entered in kHz.

It's Used In The Following Test:

[**TEST_17. RX CTCSS/CDCSS Opening**](#)

Parameter 18. RX Nominal Audio Power

This test parameter is used to set the rated audio-output power for the receiver in order for the software to determine the full-scale volume level of the meter screen displayed on the Test Set during testing. Also, this test parameter is used by the software whenever:

- the radio's squelch control is adjusted.
- the radio's volume and/or squelch control is adjusted to its maximum or minimum values.
- the radio's squelch sensitivity is to be found.

For Example:

If the audio-output power for your receiver is rated at 5 Watts, you would enter 5 in the value column. The value must be entered in Watts. The meter screen shown during testing will show a full-scale volume level of 15 Watts since the level is scaled up by 50%.

It's Used In The Following Tests:

- [TEST_11. RX Noise and Hum](#)
- [TEST_12. RX Audio Distortion](#)
- [TEST_13. RX Frequency Response](#)
- [TEST_14. RX Usable Sensitivity](#)
- [TEST_15. RX Amplitude Characteristics](#)
- [TEST_16. RX Audio Squelch Sensitivity](#)
- [TEST_17. RX CTCSS/CDCSS Opening](#)
- [TEST_18. RX Quick Test](#)

Parameter 19. RX Set Radio Volume

This test parameter allows you to have the software prompt the test operator to adjust volume on the radio during testing or to allow the software to take the volume setting where it is.

You can decrease testing time by setting this test parameter to **0=no** if you are willing to let all tests run at the same volume (audio) level. The industry standard often requires adjusting volume to specific volume levels.

For example:

If you want the test operator to be able to adjust radio volume during testing, you would enter **1** in the value column. If you want the Test Set to take the volume setting as it is, you would enter **0** in the value column.

It's Used In The Following Tests:

ALL TESTS. Whenever the radio's volume is adjusted for a maximum or minimum level.

Parameter 20. RX Squelch Control

Depending upon how you set this test parameter, the test operator is either prompted to adjust the squelch control on the radio during testing, or the software is allowed to take the squelch setting where it is at.

For example:

If you want the test operator to be able to adjust radio squelch during testing, you would enter **1** in the value column. If you want the Test Set to take the squelch setting as it is, you would enter **0** in the value column.

It's Used In The Following Tests:

ALL TESTS. Whenever the test operator is prompted to adjust the radio squelch control.

Parameter 21. RX Squelch Preset Only

This test parameter allows you to use the preset squelch setting on the radio, in which case, the test operator is not prompted to adjust the squelch setting. For radios without an adjustable squelch knob, you'll want to set this test parameter to 1.

For Example:

If you want to use the receiver's preset setting for squelch, enter 1 in the value column. If you want to allow the test operator to adjust squelch during testing, enter 0 in the value column.

It's Used In The Following Test:

[TEST_16. RX Audio Squelch Sensitivity](#)

Parameter 22. RX Tolerance For Setting Volume

This test parameter sets a tolerance window for the maximum percentage of error allowed on the meter screen. The meter screen is displayed on the Test Set during testing for manually setting the radio's volume. The tolerance for setting volume should be as accurate as the radio's volume control will allow.

For Example:

For example, if maximum audio power is 10 watts (set up in test [Parameter 18. RX Nominal Audio Power](#)) the meter screen on the HP 8920A will display a full-scale reading of 15 Watts since the software scales the meter screen by 50%. The tolerance window displayed on the meter screen will be a percentage of the 10 Watts. In this example, test [Parameter 22. RX Tolerance For Setting Volume](#) set to "10%" would create a tolerance window of 1 Watt, "5%" would create a tolerance window of 0.5 Watts, and so forth.

The value should be determined based on the highest accuracy the radio volume control allows. Enter a number equal to the accuracy you want and then run a test to see if the radio volume control allows you to make the setting. If you can not adjust the volume within the tolerance window, enter a larger number. The value is entered in % error.

It's Used In The Following Tests:

- [TEST_11. RX Noise and Hum](#)
- [TEST_12. RX Audio Distortion](#)
- [TEST_13. RX Frequency Response](#)
- [TEST_14. RX Usable Sensitivity](#)
- [TEST_16. RX Audio Squelch Sensitivity](#)
- [TEST_17. RX CTCSS/CDCSS Opening](#)
- [TEST_18. RX Quick Test](#)

Parameter 23. RX Usable Sens Set And Meas

This test parameter allows you to choose how the test for usable sensitivity will be performed.

For Example:

Setting this test parameter to “0” causes the software to perform a pass/fail measurement of the receiver’s usable sensitivity. In this case, the Test Set RF generator’s output level is set to the upper limit of [Pass/Fail Limit 11. RX Usable Sensitivity](#) and the measured SINAD level at the radio’s output is checked against test [Parameter 24. RX Usable Sensitivity SINAD Level](#). If the SINAD level is within the specified limits the test passes and the specified usable sensitivity from [Pass/Fail Limit 11. RX Usable Sensitivity](#) is displayed in the “**Measured value**” column.

Setting this test parameter to “1” causes the software to perform a faster, iterative measurement of usable sensitivity. In this case, usable sensitivity is measured by setting the RF level to the upper limit of [Pass/Fail Limit 11. RX Usable Sensitivity](#). The Test Set RF generator’s output level is varied until the SINAD level measured at the radio’s output. The SINAD level measured is displayed in the “**Measured value**” column as the usable sensitivity SINAD level.

It’s Used In The Following Tests:

- [TEST_14. RX Usable Sensitivity](#)
- [TEST_18. RX Quick Test](#)

Parameter 24. RX Usable Sensitivity SINAD Level

This test parameter sets the Test Set RF generator's output level to the standard signal-to-noise ratio (SINAD) which is used in receiver sensitivity testing.

For Example:

If your industry standard specifies the standard SINAD ratio as 20 dB, you would enter **20** in the value column. The value is entered in dB.

It's Used In The Following Tests:

[TEST_14. RX Usable Sensitivity](#)

[TEST_18. RX Quick Test](#)

Parameters 25-27. TX Audio Freq Response Start, Stop and Step Frequencies

The start frequency test parameter sets the lowest modulation frequency used for testing the transmitter's audio frequency response.

The step frequency test parameter sets the step size used to vary the modulation frequency for testing the transmitter's audio frequency response.

The stop frequency test parameter sets the highest modulation frequency used for testing the transmitter's audio frequency response.

For Example:

If your industry standard determines that the modulation frequency used for testing the transmitter's audio frequency response should start at 300 Hz and stop at 3 kHz in 500 Hz steps, you would enter:

- 0.3 in the value column for test parameter 25.
- 0.5 in the value column for test parameter 26.
- 3 in the value column for test parameter 27.

The values must be entered in kHz.

It's Used In The Following Tests:

[TEST_06. TX Audio Frequency Response](#)
[TEST_19. TX Quick Test](#)

Parameter 28. TX CT/CDCSS Available

This test parameter lets the Test Set know that the radio transmits a carrier modulated with a CTCSS tone code. With CDCSS, this test parameter lets the Test Set know that a code word is available.

Besides being used in the test shown below, this test parameter affects all transmitter tests by prompting the test operator to disable the transmitter's tone squelch before continuing with testing.

For Example:

If you want the transmitted CTCSS tone code tested for deviation and frequency accuracy or if you want the Test Set to know that a code word is available, you would enter **1** in the value column, otherwise, enter **0** in the value column.

It's Used in the Following Tests:

TEST_10. TX CTCSS/CDCSS Deviation, Freq/Code

All transmitter tests when CTCSS is available (when this test parameter is set to 1).

Parameter 29. TX CTCSS/CDCSS Control

This test parameter allows the transmitted CTCSS tone code or transmitted CDCSS code word to be controlled by the test operator.

This test parameter affects all transmitter tests in that if the radio uses CTCSS/CDCSS squelch and you indicate that no control is available, then the software does not prompt the test operator to disable the transmitter's squelch during testing but continues testing regardless whether or not the tone is on or off, or if the code word is applied.

For Example:

If you want to prompt the test operator to disable the squelch during testing, you would enter **1** in the value column, otherwise, enter **0** in the value column.

It's Used In The Following Tests:

All transmitter tests when CTCSS/CDCSS is available (as indicated by test parameter 28).

Parameter 30. TX CT/CDCSS Filter 1 Opt

This test parameter allows the CT/CDCSS filter (HP 8920A Option 010, 400 Hz High-Pass Filter) to be used by the Test Set *if one is installed*. If the CT/CDCSS filter is installed, “**CCITT**” appears in the AF Analyzer **Filter 1** field.

For Example:

If you want the installed CT/CDCSS filter to be used during receiver and transmitter testing, you would enter **1** in the value column, otherwise, enter **0** in the value column.

It's Used in the Following Tests:

All tests when the 400 Hz High-Pass Filter is installed in the Test Set.

Parameter 31. TX De-emphasis

De-emphasis refers to the network at the input of the Test Set AF Analyzer which is designed to restore the received, pre-emphasized f signal. If this test parameter is turned on, a 750 μ sec de-emphasis filter is activated.

For Example:

If your industry standard requires the “standard test receiver” to use a 750 μ sec de-emphasis filter, you would enter **1** in the value column, otherwise, you would enter **0** to have de-emphasis off.

It’s Used In The Following Tests:

TEST_07. TX Audio Distortion
TEST_09. TX Residual Modulation
TEST_19. TX Quick Test

All transmitter tests when CTCSS is available (when this test parameter is set to 1)

Parameter 32. TX Dekey Between TX Tests

This test parameter forces test operator to de-key the radio between each transmitter (TX) test or to allow the radio to transmit continuously.

For Example:

If you want the Test Procedure sequence to proceed as quickly as possible and are not concerned that the radio transmits continuously between tests or if your radio has a transmitter with an automatic timeout feature which de-keys the radio, you would enter **0** in the value column, otherwise, enter **1** in the value column.

It's Used in the Following Tests:

All transmitter tests if this test parameter is turned on (that is, set to 1).

Parameters 33-35. TX Freq Dev Start, Step, and Stop Freq For Audio Band

These test parameters sets the start, step, and stop frequency for testing the transmitter's frequency deviation. When frequency deviation is measured the modulation frequency is varied between the lowest start frequency set by this test parameter and then increased by steps up to the stop frequency value.

For Example:

If you want to test for transmitter deviation starting at 300 Hz, and ending at 3 kHz in 500 Hz steps, you would enter the following in the value columns: (All values must be entered in kHz.)

- 0.3 in the value column for test parameter 33.
- 0.5 in the value column for test parameter 34.
- 3 in the value column for test parameter 35.

It's Used In The Following Tests:

TEST_05. TX Frequency Deviation

TEST_19. TX Quick Test

Parameter 36. TX Freq Dev Tested >3 kHz

This test parameter allows you to test the response of the transmitter to modulation frequencies exceeding 3 kHz.

For Example:

If your radio specification indicates that transmitter frequency deviation should be tested with modulation frequencies greater than 3 kHz, you would enter 1 (yes) in the value column.

It's Used In The Following Tests:

[TEST_05. TX Frequency Deviation](#)

[TEST_19. TX Quick Test](#)

Parameter 37. TX Mic Sensitivity Level

This test parameter sets the level that is applied at a 1 kHz rate to the radio for measuring microphone sensitivity.

For Example:

If your industry standard recommends applying a 155 mVrms voltage to the radio to measure microphone sensitivity, you would enter **155** in the value column. The value must be entered in mVrms.

It's Used In The Following Tests:

[TEST_08. TX Microphone Sensitivity](#)

[TEST_19. TX Quick Test](#)

Parameter 38. TX Output Power @Low Switch

This test parameter allows you to test for transmitter output power with the power supply voltage set to its low-switch setting.

For Example:

If your radio has a high/low-switch setting and you want to test the transmitter for output power at the low switch setting, you would enter **1** in the value column, otherwise, enter **0** in the value column.

It's Used In The Following Tests:

[TEST_03. TX Output Power Error](#)

[TEST_19. TX Quick Test](#)

Parameter 39. TX User/System Key UUT

This test parameter allows you to determine if the test operator (user) should key the transmitter or if the Test Set (system) should key the transmitter during testing. Having the Test Set key the transmitter requires connections from the radio to the Test Set MIC/ACC connector (see ["Serial Connection," in chapter 5, on page 204](#) for a pin-out description).

For Example:

If you want the Test Set to automatically key the transmitter, you would enter **1** in the value column, otherwise, enter **0** in the value column to have the test-system operator key the transmitter.

It's Used in the Following Tests:

*All transmitter tests if this test parameter is turned on (that is, set to **1**).*

Parameter 40. XX Secure Frequency Info

This test parameter allows you to secure the radio's channel and frequency information.

This test parameter provides security for the radio by preventing the channel's frequency from being seen on the Test Set display and from being printed in the test results. Instead, the receive frequency is shown as "**RX=FXXX MHz**" and the transmit frequency is shown as "**TX=FXXX MHz**" where "**FXXX**" is the secured frequency.

For Example:

If you want to prevent the radio channel's receive and transmit frequencies from being printed with the test results, you would enter **1** in the value column, otherwise, enter **0** in the value column.

It's Used in the Following Tests:

*All tests if this test parameter is turned on (that is, set to **1**).*

Pass/Fail Limit (Specification) Descriptions

Pass/Fail Limits define the values a measurement's result is compared against to determine if the UUT meets its specified standards.

For information on editing Pass/Fail Limits, see ["Customizing Testing," in chapter 2, on page 30](#).

The list of pass/fail limits is arranged alphabetically. The first few capital letters in the title indicate what the pass/fail limit refers to (see Prefixes and Abbreviations at the beginning of this chapter).

Pass/Fail Limits remain in battery-backed-up memory until you select a procedure to run. If you wish to prevent them from being lost when a new procedure is selected you will have to save them in a procedure. See ["Saving a Test Procedure," in chapter 2, on page 48](#). To print the list of Pass/Fail Limits, see ["To print TESTS screens;," in chapter 5, on page 210](#).

There are two types of pass/fail limits:

- Receiver Test Pass/Fail Limits (RX)
- Transmitter Test Pass/Fail Limits (TX)

NOTE: Refer to [chapter 2](#) for details about selecting pass/fail limits for your FM radio.

Pass/Fail Limit 1. RX Amplitude Characteristics Change

This pass/fail limit sets the pass/fail limits for testing the receiver's amplitude characteristics. For a specified change in RF input level, the change in audio-output level should not exceed the limits you specify between the maximum and minimum output levels.

Pass/fail limits are determined from an applicable industry standard, such as:

- Industry standard: CEPT T/RA-24-01 Section 5.2, and ETS [B] Section 8.3, *Amplitude Characteristics of Receiver*

For Example:

If your industry standard states that the change of audio-output level shall not exceed 3 dB between the maximum and minimum output levels and you want to test the radio's upper limits, you would enter **0** in the lower-limit column and **3** in the upper-limit columns. Limits are entered in dB.

It is Used in the Following Tests:

- [TEST_15. RX Amplitude Characteristics](#)
- [TEST_18. RX Quick Test](#)

Pass/Fail Limit 2. RX Audio Distortion

This defines pass/fail limit values for testing receiver audio distortion when the radio's volume is set to two RF input-signal levels.

Pass/fail limits are determined from an applicable radio specification or industry standard, such as:

- Radio specification: Audio Distortion
- Industry standard: CEPT T/RA-24-01, Section II 9.0, *Harmonic Distortion*

For Example:

If your industry standard defines that the harmonic distortion should not exceed 10% at all audio frequencies and you want to test the radio's upper limits only, you would enter **0** in the lower-limit column and **10** in the upper-limit column. Limits are entered in %.

It is Used in the Following Tests:

- [TEST_12. RX Audio Distortion](#)
- [TEST_18. RX Quick Test](#)

Pass/Fail Limit 3. RX Audio Freq Resp Delta From 6 dB/oct

This defines pass/fail limits for testing receiver audio-frequency response, with squelch set to minimum and volume set to 50% of rated audio-output power.

Pass/fail limits are determined from an applicable radio specification or industry standard, such as:

- Radio specification: Audio Response
- Industry standard: CEPT T/RA-24-01, Section II 8.0, *Audio Frequency Response of the Receiver*

For Example:

If your radio specification defines receiver audio-frequency response to be within +1 and -3 dB of a 6 dB/octave de-emphasis curve and you want to test both limits on the radio, you would enter -3 in the lower-limit column and 1 in the upper-limit column. Limits are entered in dB.

It is Used in the Following Tests:

- [TEST_13. RX Frequency Response](#)
- [TEST_18. RX Quick Test](#)

Pass/Fail Limit 4. RX CT/CDCSS Opening Level

This pass/fail limit sets the opening level for the RF signal applied to the receiver input (with the squelch tone on for CTCSS or the code word applied for CDCSS) that causes the radio to de-squelch.

This pass/fail limit is used with [Pass/Fail Limit 5. RX CT/CDCSS SINAD At Opening](#) to set the pass/fail limits for testing receiver CTCSS and CDCSS opening.

Pass/fail limits are determined from an applicable radio specification or industry standard, such as:

- Radio specification: Threshold Squelch Sensitivity
- Industry standard: CEPT T/RA-24-01

For Example:

If your radio specification defines the Threshold Sensitivity as 0 dB μ V EMF and you want to test the radio's upper limits, you would enter 0 in the lower-limit column and 0 in the upper-limit column. Limits are entered in dB μ V EMF.

It's Used in the Following Test:

[TEST_17. RX CTCSS/CDCSS Opening](#)

Pass/Fail Limit 5. RX CT/CDCSS SINAD At Opening

”CTCSS/CDCSS SINAD at opening” refers to the SINAD measured at the opening level of the squelch tone.

This pass/fail limit is used with **Pass/Fail Limit 4. RX CT/CDCSS Opening Level** to set the pass/fail limits for testing receiver CTCSS/CDCSS opening.

Pass/fail limits are determined from an applicable radio specification or industry standard, such as:

- Radio specification: Threshold Squelch Sensitivity
- Industry standard: CEPT T/RA-24-01

For Example:

If your industry standard defines the tone-squelch opening SINAD as less than 8 dB for CTCSS and you want to test the radio’s upper limits only, you would enter **0** in the lower-limit column and **8** in the upper-limit column. Limits are entered in dB.

It’s Used in the Following Test:

TEST_17. RX CTCSS/CDCSS Opening

Pass/Fail Limit 6. RX Noise and Hum

This sets the pass/fail limits for receiver noise and hum testing. Audio frequency noise and hum results from the spurious effects of the radio's power supply or from other causes to the audio-frequency power when the RF signal is modulated by the receiver's input signal.

Pass/fail limits are determined from an applicable radio specification or industry standard, such as:

- Radio specification: Noise and Hum
- Industry standard: CEPT T/RA-24-01, Section II 10.0, "*Noise and Hum*" of the *Receiver*

For Example:

If your industry standard specifies that the ratio of Noise and Hum to the modulation signal should not exceed -40 dB and you want to test the radio's upper limit, you would enter 0 in the lower-limit column and -40 in the upper-limit column. Limits are entered in dB.

It's Used in the Following Tests:

- [TEST_11. RX Noise and Hum](#)
- [TEST_18. RX Quick Test](#)

Pass/Fail Limit 7. RX SINAD Audio Level Change at Extremes

This sets the pass/fail limits for testing the variation of the receiver's output power for usable sensitivity under normal testing conditions when the measurement is done at the high and low supply voltages.

Pass/fail limits are determined from an applicable radio specification or industry standard, such as:

- Radio specification: Usable Sensitivity
- Industry standard: CEPT T/RA-24-01 Section 5.1, and ETS [B] Section 8.1, *Maximum Usable Sensitivity*

For Example:

If your industry standard indicates that under extreme test conditions, a variation of the receiver's output power of ± 3 dB is acceptable and you want to test both limits on the radio, you would enter -3 in the lower-limit column and 3 in the upper-limit column. Limits are entered in dB.

It's Used In The Following Tests:

[TEST_14. RX Usable Sensitivity](#)

[TEST_18. RX Quick Test](#)

Pass/Fail Limit 8. RX Stand-by Current Drain

This sets the pass/fail limits for testing receiver stand-by current drain (with squelch set to maximum).

Pass/fail limits are determined from an applicable radio specification, such as:

- Radio specification: Maximum Battery Drain

For Example:

If your radio specification sets the maximum battery drain, while the radio is receiving, as 0.5 amperes and you want to test the radio's upper limits, you would enter 0 in the lower-limit column and 0.5 in the upper-limit column. Limits are entered in amps.

It's Used In The Following Test:

[TEST_01. TX and RX Stand-by Current Drain](#)

Pass/Fail Limit 9. RX Threshold Squelch Sensitivity

This sets the pass/fail limits for testing audio-squelch sensitivity, with squelch and volume adjusted for the threshold and tight-squelch settings.

Pass/fail limits are determined from an applicable radio specification, such as:

- Radio specification: Audio Squelch Sensitivity

For Example:

If your radio specification sets audio-squelch sensitivity to be 1 dB μ V EMF and you want to test the radio's upper limit, you would enter 0 in the lower-limit column and 1 in the lower-limit column. Limits are entered in dB μ V EMF.

It's Used In The Following Test:

[TEST_16. RX Audio Squelch Sensitivity](#)

Pass/Fail Limit 10. RX Tight Squelch Sensitivity

This sets the pass/fail limits for testing the receiver's tight-squelch sensitivity in the audio-squelch sensitivity test.

Pass/fail limits are determined from an applicable radio specification, such as:

- Radio specification: *Audio Squelch Sensitivity*

For Example:

If your radio specification defines “tight” Audio Squelch Sensitivity to be less than 26 dB μ V EMF and you want to test the radio's upper limits, you would enter 0 in the lower-limit column and 26 in the upper-limit column. Limits are entered in dB μ V EMF.

It's Used In the Following Test:

[TEST_16. RX Audio Squelch Sensitivity](#)

Pass/Fail Limit 11. RX Usable Sensitivity

This sets the pass/fail limits for testing the receiver's usable sensitivity.

Pass/fail limits are determined from an applicable radio specification or industry standard, such as:

- Radio specification: Sensitivity
- Industry standard: CEPT T/RA-24-01 Section 5.1 and ETS [B] Section 8.1, *Maximum Usable Sensitivity*

For Example:

If your industry standard specifies that the maximum usable sensitivity should not exceed +6dB μ V EMF and you want to test the radio's upper limits, you would enter 0 in the lower-limit column and 6 in the upper-limit column. Limits are entered in dB μ V EMF.

It's Used in the Following Tests:

- [TEST_14. RX Usable Sensitivity](#)
- [TEST_18. RX Quick Test](#)

Pass/Fail Limit 12. RX Usable Sensitivity At Extremes

This sets the pass/fail limits for testing the receiver's usable sensitivity at high and low-supply voltages for extreme measurements if a programmable power supply is configured to the Test Set.

Pass/fail limits are determined from an applicable radio specification or industry standard, such as:

- Radio specification: Sensitivity
- Industry standard: CEPT T/RA-24-01 Section 5.1 and ETS [B] Section 8.1, *Maximum Usable Sensitivity*

For Example:

If your industry standard specifies that the maximum usable sensitivity tested at extreme supply voltages should not exceed +12dB μ V EMF and you want to test the radio's upper limits, you would enter **0** in the lower-limit column and **12** in the upper-limit column. Limits are entered in dB μ V EMF.

Used In The Following Tests:

[TEST_14. RX Usable Sensitivity](#)

[TEST_18. RX Quick Test](#)

Pass/Fail Limit 13. TX Audio Distortion

This sets the pass/fail limits for testing transmitter audio distortion.

Pass/fail limits are determined from an applicable radio specification or industry standard, such as:

- Radio specification: Audio Distortion
- Industry standard: CEPT T/RA-24-01, Section II 6.2, *Harmonic Distortion Factor in Transmission*

For Example:

If your industry standard defines that the harmonic distortion factor should not exceed 10% and you want to test the radio's upper limits, you would enter **0** in the lower-limit column and **10** in the upper-limit column. Limits are entered in %.

It's Used In The Following Tests:

[TEST_07. TX Audio Distortion](#)

[TEST_19. TX Quick Test](#)

Pass/Fail Limit 14. TX Audio Modulation Index Error

This sets the pass/fail limits for testing the transmitter's audio-frequency response. The modulation index error is the ratio of:

- the measured frequency deviation,
- to the modulation frequency at which the deviation is measured.

The reference for each measurement is taken at a 1 kHz rate.

Pass/fail limits are determined from an applicable radio specification or industry standard, such as:

- Radio specification: Audio Frequency Response
- Industry standard: CEPT T/RA-24-01, Section II 5.2.2, *Audio Frequency Response of Transmitter*

For Example:

If your industry standard defines frequency deviation, when testing transmitter audio-frequency response, to be constant and equal to its value at a 1 kHz rate within +1 dB and -3 dB and you want to test both limits on the radio, you would enter 1 in the lower-limit column and -3 in the upper-limit column. Limits are entered in dB.

It's Used In The Following Tests:

- [TEST_06. TX Audio Frequency Response](#)
- [TEST_19. TX Quick Test](#)

Pass/Fail Limit 15. TX CT/CDCSS Deviation

This sets the pass/fail limits for testing the transmitter's Continuous Tone-Controlled Squelch System (CTCSS) and Continuous Digital-Controlled Squelch System (CDCSS) deviation.

Pass/fail limits are determined from an applicable radio specification, such as:

- Radio specification: CTCSS/CDCSS Deviation

For Example:

If your radio specification defines the limits for CTCSS deviation to be between 0.5 to 1.0 kHz and you want to test both limits, you would enter **.5** in the lower-limit column and **1.0** in the upper-limit column. Limits are entered in kHz.

It's Used In The Following Test:

TEST_10. TX CTCSS/CDCSS Deviation, Freq/Code

Pass/Fail Limit 16. TX CTCSS Frequency Error

This sets the pass/fail limits for testing the transmitter's Continuous-Tone-Controlled Squelch System (CTCSS) frequency error.

Pass/fail limits are determined from an applicable radio specification, such as:

- Radio specification: CTCSS Frequency Error

For Example:

If your radio specification defines the limits for CTCSS frequency error to be $\pm 5\%$ and you want to test both limits, you would enter -5 in the lower-limit column and 5 in the upper-limit column. Limits are entered in %.

It's Used In The Following Test:

[TEST_10. TX CTCSS/CDCSS Deviation, Freq/Code](#)

Pass/Fail Limit 17. TX Current Drain

This sets the pass/fail limits for testing the transmitter's current drain.

Pass/fail limits are determined from an applicable radio specification, such as:

- Radio pass/fail: Maximum Battery Drain, Transmit at Rated Power

For Example:

If your radio specification sets the Maximum Battery Drain while the radio is transmitting to be 5 amperes and you want to test the radio's upper limits, you would enter 0 in the lower-limit column and 5 in the upper-limit column. Limits are entered in Amps.

It's Used In The Following Tests:

ALL TESTS. Whenever a system initialization is done.
[TEST_01. TX and RX Stand-by Current Drain](#)

Pass/Fail Limit 18. TX Frequency Deviation

This sets the pass/fail limits for testing the transmitter's frequency deviation.

Pass/fail limits are determined from an applicable radio specification or industry standard, such as:

- Radio specification: Frequency Deviation
- Industry standard: CEPT T/RA-24-01 Section 4.3 and ETS [B] Section 7.4, *Frequency Deviation*

For Example:

If your industry standard defines the maximum permissible frequency deviation to be ± 5 kHz and you want to test the radio's upper limits, you would enter 0 in the lower-limit column and 5 in the upper-limit column. Limits are entered in kHz.

It's Used In The Following Test:

[TEST_05. TX Frequency Deviation](#)

Pass/Fail Limit 19. TX Frequency Error

This defines the pass/fail limits when testing the transmitter's frequency error, and as a reference value when testing the receiver's audio distortion and audio-frequency response.

Pass/fail limits are determined from an applicable radio specification or industry standard, such as:

- Radio specification: Frequency Stability
- Industry standard: CEPT T/RA-24-01 Section 4.1 and ETS [B] Section 7.1, *Frequency Error*

For Example:

If your industry standard defines frequency error to not exceed ± 2 kHz and you want to test both limits on the radio, you would enter -2 in the lower-limit column and 2 in the upper-limit column. Limits are entered in kHz.

It's Used In the Following Tests:

[TEST_02. TX Frequency Error](#)
[TEST_12. RX Audio Distortion](#)
[TEST_13. RX Frequency Response](#)
[TEST_19. TX Quick Test](#)

Pass/Fail Limit 20. TX Mic Sensitivity

This sets the pass/fail limits for testing transmitter microphone sensitivity. Microphone sensitivity is the nominal voltage measured at the input of the microphone that will cause full-rated system deviation of the transmitter. The value for full-rated system deviation is set by test [Parameter 5. RT Full Rated System Deviation](#).

Pass/fail limits are determined from an applicable radio specification or industry standard, such as:

- Radio specification: Microphone Sensitivity
- Industry Standard: CEPT T/RA-24-01, Section II 4.0, *Sensitivity of Modulator, including Microphone*

For Example:

If your industry standard defines the “normal speech level” applied to the microphone to sufficiently modulate the transmitter as a value between 60% and 90% of the full-rated system deviation and you want to test both limits on the radio, you would enter **60** in the lower-limit column and **90** in the upper-limit column. Limits are entered in %.

It's Used In The Following Tests:

[TEST_08. TX Microphone Sensitivity](#)

[TEST_19. TX Quick Test](#)

This pass/fail limit is also used as a reference value whenever transmitter deviation is set during testing.

Pass/Fail Limit 21. TX Modulation Limiting

This sets the pass/fail limits for testing the transmitter's modulation limiting.

Pass/fail limits are determined from an applicable radio specification or industry standard, such as:

- Radio specification: Modulation Limiting
- Industry standard: CEPT T/RA-24-01 Section II 3.0, and ETS [B] Section 7.4, *Limitation Characteristics of Transmitter Modulator*

For Example:

If your industry standard defines that the transmitter's frequency deviation must remain between 70% and 100% of the full-rated system deviation (set by test [Parameter 5. RT Full Rated System Deviation](#)) and you want to test both limits on the radio, you would enter **70** in the lower-limit column and **100** in the upper-limit column. Limits are entered in %.

It's Used In The Following Test:

[TEST_04. TX Modulation Limiting](#)

Pass/Fail Limit 22. TX Output Power Error

This sets the pass/fail limits for testing the transmitter's output-power error at its normal-power setting.

Pass/fail limits are determined from an applicable radio specification or industry standard, such as:

- Radio specification: RF Power
- Industry standard: CEPT T/RA-24-01 Section 4.2, and ETS [B] Section 7.2, *Carrier Power*

For Example:

If your industry standard defines the limits for carrier output-power error under normal test conditions to be within ± 1.5 dB of the rated power output and you want to test both limits on the radio, you would enter -1.5 in the lower-limit column and 1.5 in the upper-limit column. Limits are entered in dB.

It's Used In The Following Tests:

- [TEST_03. TX Output Power Error](#)
- [TEST_19. TX Quick Test](#)

Pass/Fail Limit 23. TX Output Power Error @ High Supply

This sets the pass/fail limits for testing the transmitter's output-power error at its high-power setting if an external power supply is used.

Pass/fail limits are determined from an applicable radio specification or industry standard, such as:

- Radio specification: Power Requirements
- Industry standard: CEPT T/RA-24-01 Section 4.2, and ETS [B] Section 7.2, *Carrier Power*

For Example:

If your industry standard defines the limits for carrier output power under extreme test conditions to be within +2 dB and -3 dB of the rated output power and you want to test both limits on the radio with the power supply at its high-power setting, you would enter -3 in the lower-limit column and 2 in the upper-limit column. Limits are entered in dB.

It's Used In The Following Tests:

- [TEST_03. TX Output Power Error](#)
- [TEST_19. TX Quick Test](#)

Pass/Fail Limit 24. TX Output Power Error @High Supply Lo SW

This sets the pass/fail limits for testing the transmitter's output-power error at its low-switch setting (if equipped with dual-power modes) with the power supply set to its high-power setting.

Pass/fail limits are determined from an applicable radio specification or industry standard, such as:

- Radio specification: Power Requirements
- Industry standard: CEPT T/RA-24-01 Section 4.2, and ETS [B] Section 7.2, *Carrier Power*

For Example:

If your industry standard defines the limits for carrier output power under extreme test conditions to be within +2 dB and -3 dB of the rated output power and you want to test both limits on the radio with the power supply at its high-power setting, you would enter -3 in the lower-limit column and 2 in the upper-limit column. Limits are entered in dB.

It's Used In The Following Tests:

- [TEST_03. TX Output Power Error](#)
- [TEST_19. TX Quick Test](#)

Pass/Fail Limit 25. TX Output Power Error @Low Supply

This sets the pass/fail limits for testing the transmitter's output-power error at the low-power setting if an external power supply is used.

Pass/fail limits are determined from an applicable radio specification or industry standard, such as:

- Radio specification: Power Requirements
- Industry standard: CEPT T/RA-24-01 Section 4.2, and ETS [B] Section 7.2, *Carrier Power*

For Example:

If your industry standard defines the limits for carrier output power under extreme test conditions to be within +2 dB and -3 dB of the rated output power and you want to test both limits on the radio with the power supply at its low-power setting, you would enter -3 in the lower-limit column and 2 in the upper-limit column. Limits are entered in dB.

It's Used In The Following Tests:

- [TEST_03. TX Output Power Error](#)
- [TEST_19. TX Quick Test](#)

Pass/Fail Limit 26. TX Output Power Error @Low Supply Lo SW

This sets the pass/fail limits for testing the transmitter's output-power error at its low-switch setting (if equipped with dual-power modes) with the power supply set to its low-power setting.

Pass/fail limits are determined from an applicable radio specification or industry standard, such as:

- Radio specification: Power Requirements
- Industry standard: CEPT T/RA-24-01 Section 4.2, and ETS [B] Section 7.2, *Carrier Power*

For Example:

If your industry standard defines the limits for carrier output power under extreme test conditions to be within +2 dB and -3 dB of the rated output power and you want to test both limits on the radio with the power supply at its low-power setting, you would enter -3 in the lower-limit column and 2 in the upper-limit column. Limits are entered in dB.

It's Used In The Following Tests:

- [TEST_03. TX Output Power Error](#)
- [TEST_19. TX Quick Test](#)

Pass/Fail Limit 27. TX Output Power Error Low Switch Setting

This sets the pass/fail limits for testing the transmitter's output-power error at its low-power setting (if equipped with dual-power modes).

Pass/fail limits are determined from an applicable radio specification or industry standard, such as:

- Radio specification: RF Power
- Industry standard: CEPT T/RA-24-01 Section 4.2, and ETS [B] Section 7.2, *Carrier Power*

For Example:

If your industry standard defines the limits for carrier output-power error under normal test conditions to be within ± 1.5 dB of the rated power output and you want to test both limits on the radio, you would enter -1.5 in the lower-limit column and 1.5 in the upper-limit column. Limits are entered in dB.

It's Used In The Following Tests:

- [TEST_03. TX Output Power Error](#)
- [TEST_19. TX Quick Test](#)

Pass/Fail Limit 28. TX Residual Modulation

This sets the pass/fail limits for testing the transmitter's residual modulation.

Pass/fail limits are determined from an applicable radio specification or industry standard, such as:

- Radio specification: Residual Modulation
- Industry standard: CEPT T/RA-24-01 Section II 7.0, *Residual Modulation of the Transmitter*

For Example:

If your industry standard states that residual modulation should not exceed -40 dB and you want to test the radio's upper limits, you would enter 0 in the lower-limit column and -40 in the upper-limit column. Limits are entered in dB.

It's Used In The Following Tests:

[TEST_09. TX Residual Modulation](#)

[TEST_19. TX Quick Test](#)

5

Reference (Alphabetical)

This chapter provides detailed descriptions of the features and functions of the HP 11807A,E software. Topics are arranged alphabetically for quick, easy reference.

Conventions Used

Special presentations of text in this manual reflect the appearance of the item being referred to.

Examples of these special presentations are:

TESTS

A key on the test set.

Procedure:

Characters displayed on the CRT display.

k1 (**Run Test**)

*A USER key, in the key column next to the CRT. **Run Test** is displayed on the CRT.*

0.000000

A field on the CRT where entries can be made.

Titles of documentation are printed in **bold**.

The term test set refers to the HP 8920A,B,D. In the steps in this manual the following words are used to describe cursor and entry actions:

- **select** refers to pressing the knob after positioning the cursor in front of the appropriate field (**inverse video** area).
- **choose** means to position the cursor in front of an item in the **Choices:** or **To Screen** menu in the lower right corner of the CRT display, and then press the knob.
- **enter** means to use the numeric keypad, and the ENTER key or measurement units keys to make entries to fields. In some procedures, **enter** is used to describe the action of entering characters into a field.

Copying Files

Files can be copied from one mass-storage device to another using IBASIC COPY commands. For example, to copy a file from an inserted memory card to the left drive of an external dual-disk drive with HP-IB address 700, press TESTS. Select **IBASIC Cntrl** from the **SET UP TEST SET** list (or **IBASIC** from the **Test Function** field). Position the cursor to the IBASIC command line and select it. Using the character list that appears in the **Choices** menu, enter the following command:

```
COPY "MY_TEST:INTERNAL" TO "MYFILE:,700,0"
```

You can copy a file from a memory card to an SRAM memory card by loading the program from the memory card into the test set, inserting an initialized SRAM memory card, and then using the IBASIC SAVE command. Enter the following:

```
SAVE "MY_TEST:INTERNAL"
```

You can list the names of the files stored in a memory card or disk catalog by using the IBASIC CAT command. To display a list of file names on a memory card, enter the following:

```
CAT ":INTERNAL" or CAT
```

The mass storage powers-up to memory card as a default. If you did not change this setting, then **":INTERNAL"** is optional. If you are entering many characters into the IBASIC command line, you may want to connect a terminal to the test set. See "[Configuring the Test Set for Printing](#)" on page 206. You will also want to use a terminal if you have many files to list because file names displayed with the **CAT** IBASIC command scroll past the top of the test set's CRT display and cannot be scrolled down.

IBASIC is used when writing your own programs and is not explained in this manual. If you need to write your own IBASIC programs you may acquire the following manuals:

- HP 8920A,D
 - *HP Instrument Basic User's Handbook* HP part number E2083-90000.
 - *HP 8920A Programming Manual* HP part number 08920-90220.
- HP 8920B
 - *HP Instrument Basic User's Handbook Version 2.0* HP part number E2083-90005.
 - *HP 8920B Programming Manual* HP part number 08920-90222.

See also: "[Initializing a Memory Card](#)" on page 196.

Data Collection (Saving and Retrieving Test Results)

The software has the capability to save test results to an SRAM memory card, to a disk drive, or to a PC.

Collection to a Memory Card or Disk

You will have to make entries into the **External Devices** (Edit Config) screen to describe the type of data collection you are using.

To configure External Devices entries:

1. Press TESTS
2. Select **External Devices** from the **SET UP TEST SET** list (or **Edit Cnfg** from the **Test Function** field).
3. Position the cursor to the **Calling Name** field and select it.
4. Using the list of characters in the **Choices** menu, enter **DATA C** into the **Calling Name** next to **Inst# 1**. The entry will look like:

```
1  DATA C
```

Note: For some SW revisions, DATA C will appear in the **Choices** menu. In this case, you may select DATA C, then Done instead of typing each character individually.

5. Position cursor to the **Addr** field and select it.
6. Using the DATA keypad, enter a number into **Addr**, depending on the type of storage media you will be using (press ENTER when complete):

If you are using a memory card, enter **1** into the **Addr**:

```
1  DATA C    1
```

If you are using a disk drive, enter the HP-IB disk address. For example, if the drive you are using is set to 700, then the display needs to look like:

```
1  DATA C    700
```

Calling names can be entered in any order.

The test software supports data storage on Logical Interchange Format (LIF) and Disk Operating System (DOS) disk formats. Storage can be to any of the following file types:

- ASCII files under LIF
- BDAT files under LIF
- HP-UX files under LIF
- DOS files under DOS

You will be specifying the file type with the entry you make into the **Options** field immediately below **DATA C**. If no file type is entered, and the disk format is LIF, the software will select an HP-UX file type. If no file type is entered, and the disk format is DOS, the software will select a DOS file type. For example, if you are using a DOS file and you are not using an extension on the file name, the entry on this screen will look like:

```
1  DATA C    700
```

If you are using an ASCII, BDAT or HP-UX file, you can specify the number of records allocated to the file. The DOS file is automatically updated as data is stored, so record allocation is not required. If you are using HP-UX files, you will have to enter **REC=** to establish a usable number of records. **REC=20480** sets the size to be the same as the default number of 256 byte records used for ASCII files (80×256). You can enter the **REC=** after the file type. For example, to use an ASCII file with 200 records of 256 bytes each, you will enter **ASCII REC=200** into the **Options** field.

NOTE:

For some software revisions, **REC=** and **ASCII REC=** will appear in the **Choices** menu. In this case, you may select **REC=** or **ASCII REC=**, enter the number of records using the **DATA** keypad, then select **Done**, instead of typing in each character individually.

The display will appear as follows:

```
1  DATA C    700
   ASCII REC=200
```

The default number of records, used when no **REC=** entry is made, is 80.

Items in the **Options** field can be separated by a comma or a space.

See "**Initializing a Disk**" on page 189 if using a new disk. See "**Initializing a Memory Card**" on page 196 if using a new memory card. The file types under LIF can be used by the test set's IBASIC controller and some HP workstations. The DOS format is required if you wish to use the disk with a PC.

Table 7 Data Collection (Saving/Retrieving Tests) Configuration Summary

Inst#	Calling Name Options	Model	Addr	Description
1	DATA Collection	don't care	7xx ¹	To HP-IB disk drive
1	DATA Collection	don't care	1	To memory card
Options: ²	File types of ASCII, or BDAT, or (EXT), ³ or blank, ⁴ REC=xxxxx, (number of records)	don't care	7xx ¹	LIF format LIF format DOS file type DOS or HP-UX file type ⁴ Number of records
1	DATA Collection	don't care	9	Serial to external computer (laptop)

1. xx = Last two digit of HP-IB address.
2. These options apply to disk drive and memory card data collection. They do not apply when collecting data with Addr=9.
3. A DOS file name extension. For example, the file name may be CELL1.EXT.
4. DOS is used if the disk format is DOS.HP-UX is used if the disk format is LIF.

Retrieving Data from a Memory Card

To retrieve the test results after they have been saved on an SRAM memory card, you will have to run an IBASIC program. The following is a program to transfer data from a memory card to a terminal emulator. You can type the program lines into the IBASIC command line from a terminal emulator. See "[Configuration for Terminal or PC Operation](#)" on page 187.

To enter the data retrieval program:

1. Press TESTS.
2. Select **IBASIC Cntrl** from the **SET UP TEST SET** list (or **IBASIC** from the **Test Function** field).
3. Position the cursor to the IBASIC command field (large field in the upper part of the display) and select it. From the list of characters in the **Choices** field, enter the following IBASIC program statements and commands.
4. Enter **SCRATCH** to delete the previous IBASIC program. Be sure it's saved first.
5. Enter the following program:

```
10 DIM A$(120)
```

Sets the string length to 120.

```
20 ASSIGN @File TO "RES:INTERNAL";FORMAT ON
```

Opens a path to the memory card file called "RES" (for results).

```
30 ON ERROR GOTO 80
```

Exits at end of file if an error is encountered.

```
40 LOOP
```

Extracts file contents.

```
50 ENTER @File;A$
```

Transfers part of the file to the string.

```
60 OUTPUT 9;A$
```

The string is output at the Serial port.

```
70 END LOOP
```

Goes back to get more of the file.

```
80 END
```

End of the program.

6. Press k1 (**Run**) to run the entered IBASIC program.

NOTE:

Difference between Run and Run Test

The USER (**Run**) key, assigned as a default key on the TESTS (IBASIC Controller) screen, will start an IBASIC program that is resident in the test set's memory. The USER (**Run Test**) key, assigned as a default key on the TESTS screens, will load and run the program that is called from the **Select Procedure Filename:** and **Select Procedure Location:** entries on the TESTS (Main Menu) screen.

Collection to a PC

Test results can be output through the serial port. A variety of devices can receive the data. An HP Palmtop computer, PC, laptop, or terminal can be used. A terminal emulator can log the test results to a file. Examples of terminal emulator programs are HP AdvanceLink and ProComm, a product of DataStorm Technologies, Inc.

For example: Configuring an IBM-Compatible PC with HP AdvanceLink for DOS

1. Load and run HP AdvanceLink on your PC.
2. Use the following [table 8](#), [table 9](#), and [table 10](#) to set the Global Configuration, Terminal Configuration, and Remote Configuration settings.

Table 8 **Global Configuration Settings**

FIELD	SETTING	FIELD	SETTING
Keyboard	USASCII	Memory Size	32K
Personality	HP	Plotter I/F	None
Language	English	HP Mode	Yes
Terminal Mode	Alphanumeric	Video Type	<i>Select your display type</i>
Remote to	<i>enter PC's serial port #</i>	Forms Path	<i>Enter path if used</i>
Printer I/F	None	Screen Size	<i>Enter the size</i>

Table 9 Terminal Configuration Settings

FIELD	SETTING	FIELD	SETTING
Terminal ID	2392A	Esc Xfer(N)	YES
Local Echo	OFF	ASCII 8 Bits	YES
CapsLock	OFF	FldSeparator	US
Start Col	01	BlkTerminator	RS
Bell	ON	ReturnDef	CR
XmitFnctn(A)	NO	Copy	Fields
SPOW(B)	NO	Type Ahead	NO
InhEolWrp(C)	NO	ROW Size	80
Line/Page(D)	LINE	Host Prmpt Char	D1
InhHndShk(G)	NO	Horiz. Scroll. Incr.	08
Inh DC2(H)	NO	Large [+] Key	+

Table 10 Remote Configuration Settings

FIELD	SETTING	FIELD	SETTING
Baud Rate	4800	SR(CH)	LO
Parity/Data Bits	None/8	Recv Pace	None
Eng Ack	No	Xmit Pace	None
Asterisk	OFF	CS(CB)Xmit	NO
Chk Parity	NO		

To set up for data collection to a PC:

1. Press TESTS.
2. Select **External Devices** from the **SET UP TEST SET** list (or **Edit Cnfg** from the **Test Function** field).
3. Position the cursor to the **Calling Name** field and select it.
4. Using the list of characters in the **Choices** menu, enter **DATA C** (next to **Inst# 1**):

```
1 DATA C
```
5. Position the cursor to the **Addr** field and select it.
6. Using DATA keypad, enter **9** and press ENTER :

```
1 DATA C 9
```

Calling names can be entered in any order.

Configuration for Terminal or PC Operation

It is preferable to enter long strings of characters into fields using a terminal. The characteristics of the serial port, when used for instrument control from a terminal or terminal emulator, are determined by settings on the test set's I/O CONFIGURE screen.

Set the following:

- **Serial In** to **Inst**
- **IBASIC Echo** to **On**
- **Inst Echo** to **On**

Set the remaining configuration entries to match the settings of your terminal or PC program.

Equivalent Front-Panel Control Characters

The following [table 11](#) lists the terminal/computer keystrokes that equate to front-panel controls. *Each equivalent character must be preceded by the Escape key.*

For example, to remotely access the CONFIGURE screen, you type Esc, C on your terminal/computer. (Be sure to use upper-case C for this example.)

Alternate sequences for 5 commonly-used functions are also available. Hold down the Ctrl (control) key and select the corresponding key for the desired function. (Example: Ctrl/H moves the cursor to the left one space.)

ENTER - ^J or ^M

CANCEL - ^C

BACKSPACE - ^H

KNOB_TURN_CW - ^R

KNOB_TURN_CCW - ^L

Table 11 **Equivalent Front-Panel Control Characters**

Function	Equiv. ESC Char.	Function	Equiv. ESC Char.	Function	Equiv. ESC Char.
CANCEL	!	SAVE	G	PRESET	i
PERCENT MHZ_V	(REF_SET	J	INCR_DIV_10	j
S_KHZ_MV)	METER	K	INCR_SET	k
BACKSPACE	-	AVG	L	INCR_TIMES_10	l
ENTER	.	LO_LIMIT	M	DOWN	m
RELEASE	0	HI_LIMIT	N	UP	n
K1	1	E	R	SEVEN	o
K2	2	F	S	EIGHT	p
K3	3	B	U	NINE	q
K4	4	C	V	FOUR	r
K5	5	D	W	FIVE	s
K1_PRIME	6	A	X	SIX	t
K2_PRIME	7	EEX	Z	ONE	u
K3_PRIME	8	YES_ON_OFF	[TWO	v
ASSIGN	9	NO_PPM_W]	THREE	w
KNOB_TURN_CCW	<	RX	a	ZERO	x
KNOB_TURN_CW	>	TX	b	POINT	y
MSSG	A	DUPLEX	c	PLUS_MINUS	z
HELP	B	PREV	d	OHM_PCT_DEL_DBUV	{
CONFIG	C	TESTS_MAIN	e	DB_GHZ_DBM	
HOLD	D	LOCAL	f	MS_HZ_UV	}
PRINT	E	RECALL	g		
ADRS	F	MEAS_RESET	h		

Disks

Initializing a Disk

If you are starting with a blank disk, you will have to initialize it to the format you have chosen. Disk drives require specific commands to perform initialization. The test set's IBASIC commands to initialize some disks are described here. You should verify that the drive you are using can be controlled by the test set and that you are initializing a disk using a drive or PC that has a compatible format.

To initialize a disk to LIF in an HP-IB disk drive:

1. Verify that the test set **Mode** on the I/O CONFIGURE screen is set to **Control**:
 - a. Press TESTS.
 - b. Select **IBASIC Cntrl** from the **SET UP TEST SET** list (or **IBASIC** from the **Test Function** field).
 - c. Position the cursor to the IBASIC command field and select it.
 - d. With the list of characters in the **Choices** menu, enter the following:

INITIALIZE ":,7xx,y"

where:

- xx = the HP-IB address of the disk drive, and
- y = the unit number of the drive.

To initialize a disk to DOS in an HP-IB disk drive:

Follow the procedure for the LIF format, replacing the INITIALIZE statement with **INITIALIZE "DOS: ,7xx,y"**.

Retrieving Data from a Disk

One way to retrieve the test results from a disk is to run an IBASIC program. A program to transfer data from a disk to a terminal emulator is given below. You can type it into the IBASIC command line from the terminal emulator. Be sure your program is saved, because it will be deleted from programmable memory. The file name for this example is "RES". The disk address is 700, and the drive number is 0. The entire file name is **RES:,700,0**.

To enter the data retrieval program:

1. Press TESTS.
2. Select **IBASIC Cntrl** from the **SET UP TEST SET** list (or **IBASIC** from the **Test Function** field).
3. Position the cursor to the IBASIC command field (large field in the upper part of the display) and select it. From the list of characters in the **Choices** field, enter the following IBASIC program statements and commands.
4. Enter **SCRATCH** to delete the previous IBASIC program. Be sure it's saved first.
5. Enter the following program:

```
10 DIM A$(120)
```

Sets the string length to 120.

```
20 ASSIGN @File TO "RES:,700,0"
```

Opens a path to the file called "RES" (for results).

```
30 ON ERROR GOTO 80
```

Exits at end of file if an error is encountered.

```
40 LOOP
```

Extracts file contents.

```
50 ENTER @File;A$
```

Transfers part of the file to the string.

```
60 OUTPUT 9;A$
```

The string is output at the serial port.

```
70 END LOOP
```

Goes back to get more of the file.

```
80 END
```

End of the program.

6. Press k1 (**Run**) to run the entered IBASIC program.

Exiting a Program

Do not press RX or TX to exit the program. Selecting the RX TEST or TX TEST screen causes signal paths internal to the test set to be modified. If you exit the program to a screen other than RX TEST or TX TEST, the settings necessary to resume testing will be retained.

After you have made the manual settings you want, press the DUPLEX key as a last step before continuing the software. This will cause the test set to be properly set up.

Another way to safely exit is to:

1. Press CANCEL.
2. Press DUPLEX.
3. Press SHIFT SAVE.
4. Using list of characters in the **Choices** menu, enter a register name or number.
5. Select **Done**.
6. Operate the test set manually.
7. Press RECALL.
8. Choose the name of the saved setup.
9. Press TESTS.
10. Press k2 (**Continue**).

HP-IB Control Annunciators

The words, letters, and symbols at the top right corner of the CRT display indicate these conditions:

- **R** indicates remote operation from an external controller or IBASIC program in the test set. This letter will be displayed while the software is running.
- **L** indicates that the test set is listening, and is ready to receive a manual or remote command.
- **T** indicates that the test set is talking to another HP-IB device.
- **S** indicates that a service request has been generated.
- **C** indicates that the test set is currently an active controller. Control mode is set on the I/O CONFIGURE screen. The test set must be a controller if HP-IB peripherals are to be controlled.
- ***** indicates that an IBASIC program is running, or that the IBASIC controller is executing a command.
- **?** indicates that an IBASIC program is waiting for a user response.
- **-** indicates that the IBASIC program is paused.
- **SHIFT** indicates that the SHIFT key was pressed, and that the next key entry will be shifted. (Press SHIFT again to clear).

Memory Cards

Memory cards are inserted into the slot on the test set's front panel. The memory card is powered by the test set while it is inserted. Arrows printed on the memory card and the test set's front panel indicate the direction and orientation of card insertion.

Memory cards are used to store or retrieve the following:

- Software code
- An HP-supplied Procedure, containing:
 - A default TEST sequence
 - Default test parameter values
 - Default pass/fail limit values
- A Library file
- Procedures you make, optimized for your application
- Data collection files
- Channel Information
- User defined keys

Three types of memory cards are available:

- Static Random Access Memory (SRAM)
 - SRAM cards have read and write capability. SRAM cards can be programmed and read with the test set.
- One-Time Programmable (OTP)
 - Once programmed with a suitable card programmer, OTP cards have read-only capability. OTP cards can be read with the test set, but cannot be programmed with the test set.
- Flash Memory
 - Flash cards have read and write capability. They can only be written to, or programmed with a suitable card reader/programmer. Flash memory cards cannot be written to, or programmed with a test set. Flash memory cards can be read by the test set.

NOTE: Hewlett-Packard-supplied software code and Hewlett-Packard procedure and library files are typically supplied on either OTP cards or flash cards. Flash cards can be distinguished from OTP cards by a small write protect (WP) switch in the end of the flash cards. SRAM cards also have a write protect or safe switch in the end of the card, but they also use a battery. Software and procedure/library files stored on a flash card cannot be overwritten by a test set regardless of the position of the write protect (WP) switch.

The software memory card can be removed after the program is loaded into the test set memory. The program will remain in memory after a power-down/power-up cycle, until a new program is loaded. Loading a new program will replace the existing program.

SRAM Memory Cards

A Static Random Access Memory (SRAM) Card can be used to store test results and procedures you make. The following parts can be used.

Table 12 SRAM Memory Card Products for HP 8920A,D

Memory	Product
32 kilobytes	HP 85700A
128 kilobytes	HP 85702A
256 kilobytes	HP 85704A
512 kilobytes	HP 85705A

Table 13 PCMCIA SRAM Memory Card Products for HP 8920B

Memory	Product
64 kilobytes	HP 83230A
256 kilobytes	HP 83233A
1 megabyte	HP 83231A

SRAM memory cards use a lithium battery (For HP 11807A: part number CR 2016 or HP part number 1420-0383. For HP 11807E: part number CR 2025 or HP part number 1420-0509). Programs and data will be retained for over one year if the memory card is stored at 25° C. The memory card is powered by the test set while it is inserted. Replace the battery while the memory card is inserted into a powered-up test set. To retain data and programs, it should be replaced annually. See the *HP 8920 User's Guide*. The write-protect switch on an SRAM memory card will write protect the card when it is set toward the outside of the card.

Memory Card Storage Space

Procedures use 12-16 records each. A Library uses 20-35 records. A single library must be included on the card. A record is 256 bytes. Approximately 11 kilobytes of overhead is required on each card.

Use the following formula to estimate the storage space needed:

$$\text{Storage Space(in kilobytes)} = (\text{Number of Procedures} \times 4.1) + 20$$

For example, if you want to save ten different procedures, you will need 61 kilobytes of memory. The 64 kilobyte or 128 kilobyte card is sufficient.

The storage space you need for data collection depends on the number of test results that are saved. You will need approximately 4 kilobytes per page of test results that you save. A page of test results is about 57 lines of CRT or printer output.

The storage space of smaller SRAM cards can be quickly used. If you are collecting large quantities of data, data collection using a PC or printer may be preferable.

Initializing a Memory Card

Initializing HP 11807A cards (Smart Cards) using the TESTS **Save/Delete Procedure** screen automatically defaults to LIF format. Initializing HP 11807E cards (PCMCIA) using the TESTS **Save/Delete Procedure** screen automatically defaults to DOS format. However, initializing cards from the **Save/Delete Procedure** screen is only available on HP 8920B or HP 8920A,D test sets with firmware above revision A.14.00. If these settings do not match your needs, or you have firmware below revision A.14.00, there is another method described below in which you may select the format.

- Press TESTS.
- Select **Save/Delete Procedure** from the **CUSTOMIZE TEST PROCEDURE** list.
- Insert the SRAM card in the slot on the front panel. (Make sure the switch on the card is not in the write-protected position).
- Press k3 (**Init Card**).
- Press Yes if you want to continue.

There are two ways to initialize a memory card to select the format. If you have a terminal emulator attached to the test set, you can type a command into the IBASIC command line. A second way to initialize a card is to run the ROM program RAM_MNG.

To initialize an SRAM card using IBASIC

1. Press TESTS.
2. Select **IBASIC Cntrl** from the **SET UP TEST SET** list (or **IBASIC** from the **Test Function** field).
3. Position the cursor to the IBASIC command line and select it.
4. Using the list of characters under the **Choices** menu, enter the following IBASIC command:

For LIF format: **INITIALIZE ":INTERNAL"**

For DOS format: **INITIALIZE "DOS:INTERNAL"**

To initialize an SRAM card using RAM_MNG

1. Press TESTS.
2. Position the cursor to the **Select Procedure Location** (or **Location**) field and select it.
3. From the **Choices** menu, select **ROM**.
4. Position the cursor to the **Select Procedure Filename** (or **Procedure**) field and select it.
5. From the **Choices** menu, select **IB_UTIL** (or **RAM_MNG**).
6. Press k1 (**Run Test**).
7. Follow the displayed instructions.

NOTE: Loading RAM_MNG will delete any procedure or program in memory.

Retrieving Data from a Memory Card

To retrieve the test results after they have been saved on an SRAM memory card, you will have to run an IBASIC program. The following is program to transfer data from a memory card to a terminal emulator. You can type the program lines into the IBASIC command line from a terminal emulator. See "[Configuration for Terminal or PC Operation](#)" on page 187.

To enter the data retrieval program:

1. Press TESTS.
2. Select **IBASIC Cntrl** from the **SET UP TEST SET** list (or **IBASIC** from the **Test Function** field).
3. Position the cursor to the IBASIC command field (large field in the upper part of the display) and select it. From the list of characters in the **Choices** field, enter the following IBASIC program statements and commands.
4. Enter **SCRATCH** to delete the previous IBASIC program. Be sure it's saved first.
5. Enter the following program:

```
10 DIM A$(120)
```

Sets the string length to 120.

```
20 ASSIGN @File TO "RES:INTERNAL";FORMAT ON
```

Opens a path to the memory card file called "RES" (for results).

```
30 ON ERROR GOTO 80
```

Exits at end of file if an error is encountered.

```
40 LOOP
```

Extracts file contents.

```
50 ENTER @File;A$
```

Transfers part of the file to the string.

```
60 OUTPUT 9;A$
```

The string is output at the serial port.

```
70 END LOOP
```

Goes back to get more of the file.

```
80 END
```

End of the program.

6. Press k1 (**Run**) to run the entered IBASIC program.

NOTE:

Difference between Run and Run Test

The USER (**Run**) key, assigned as a default key on the TESTS (IBASIC Controller) screen, will start an IBASIC program that is resident in the test set's memory. The USER (**Run Test**) key, assigned as a default key on the other TESTS screens, will load and run the program that is called from the **Select Procedure Filename** and **Select Procedure Location** entries on the TESTS (Main Menu) screen.

Parameters

Parameters are values you enter that optimize your use of the test software. Many of the parameters are determined by examining your test needs.

Default values are set into the software. Some of these values are derived from standard methods of measurement and some are derived from the industry standard requirements. Load a Procedure and select the **Test Parameters** screen from the **CUSTOMIZE TEST PROCEDURE** list, to see the default values.

You should verify that parameters are properly set after you select the tests to be placed in your procedure.

Parameters remain in battery-backed-up memory until you select a procedure to run. If you wish to prevent them from being lost when a new procedure is selected, you will have to save them in a procedure. See "[Saving a Procedure](#)" on [page 217](#).

To print the parameters list, see "[To print TESTS screens:](#)" on [page 210](#).

To edit a parameter value:

1. Press TESTS.
2. Select **Test Parameters** from the **CUSTOMIZE TEST PROCEDURE** list (or **Edit Parm** from the **Test Function** field).
3. Position the cursor to the **Parm#** field and select it.
4. Rotate the knob to the desired parameter number and select it.
5. Position the cursor to the **Value** field and select it.
6. Enter the desired value using the DATA keypad and press ENTER.
 - a. Use the ← key to backspace.
 - b. Press CANCEL to cancel entries and retain the old value.
7. Press k5 (**Main Menu**) (or TESTS) to return to the TESTS screen.

Pass/Fail Limits (specifications)

Pass/Fail Limits are values you enter that set passing limits for tests. Default values are available in the test software. They have been derived from standard methods of measurement.

Pass/Fail Limits do not have to be changed when you select a test or change the tests in your procedure. Each test has pass/fail limits that apply to it.

You should verify that pass/fail limits are properly set after you select the tests to be placed in your procedure. Lists of the pass/fail limits used by each of the tests are contained in the test descriptions in [chapter 4](#). A lock is provided to prevent access to the pass/fail limits. See "[Securing a Procedure](#)" on [page 220](#). Pass/fail limits remain in the test set's battery-backed-up memory until you select a procedure to run. If you wish to prevent pass/fail limits from being lost when a new procedure is selected, you will have to save them in a procedure. See "[Saving a Procedure](#)" on [page 217](#).

To print the pass/fail limits list, see "[To print TESTS screens:](#)" on [page 210](#).

To edit a pass/fail limit value:

1. Press TESTS.
2. Select **Pass/Fail Limits** from the **CUSTOMIZE TEST SET** list (or **Edit Spec** from the **Test Function** field).
3. Position the cursor to the **Spec#** field and select it.
4. Rotate the knob to the desired pass/fail limit number and select it.
5. Position the cursor to the **Lower Limit** or the **Upper Limit** field and select it.
6. Enter desired value using the DATA keypad and press ENTER.
 - a. Use the ← key to backspace.
 - b. Press CANCEL to cancel entries and retain the old value.
7. Position the cursor to the **Check** field and select it.
8. From the **Choices** menu, select the combination of upper and lower limits to be checked.

Pausing or Stopping a TEST

To pause the program, press CANCEL.

To stop the program, press SHIFT then CANCEL. This performs an IBASIC RESET operation.

NOTE:

Changing Settings while Paused

If you make changes to instrument settings while the program is paused, subsequent operation may be unpredictable. Error messages may or may not be displayed. See "[Exiting a Program](#)" on page 191.

To continue a paused program:

1. Press TESTS.
2. Press k1 (**Continue**). The test time is displayed when the test is completed. This time includes the time that the program is paused and the time that it is waiting for connection and inputs to be made. If you are testing through midnight, the test time will not display properly.

Printing

You can print any of the following:

- Test results
- TESTS screens
 - "External Devices" (Edit Cnfg)
 - "Order of Tests" (Edit Seqn)
 - "Channel Information" (Edit Freq)
 - "Pass/Fail Limits" (Edit Spec)
 - "Test Parameters" (Edit Parm)

How to Print (task list) There are five basic steps to printing listed below. A detailed description of each of these steps is at the end of this section.

1. Check to see if your printer is supported by the test set (see ["Supported Printers" on page 203](#)).
2. Determine if your printer requires serial, parallel, or HP-IB connection. Connect the printer to the appropriate port on the test set (see ["Printer Connection" on page 204](#)).
3. Configure the test set for your printer and its interface (see ["Configuring the Test Set for Printing" on page 206](#)).
4. Instruct the test set what to print (see ["To print test results:" on page 207](#)).

Supported Printers

- HP ThinkJet printer
- HP QuietJet printer
- HP PaintJet printer
- HP DeskJet printer
- HP LaserJet printer
- Epson FX-80 printer
- Epson LQ-850 printer

If you do not have one of these printers, consult your printer's manual for the correct printer settings to emulate one of the supported printers.

Printer Connection

HP-IB Connection

An HP-IB printer can be connected to the test set's rear-panel HP-IB connector with an HP-IB cable.

Serial Connection

A serial printer can be attached to the serial port. See [figure 1](#). Use the following RJ-11 pins for this connection.

- RJ-11 Pin 2 - test set Receive Data
- RJ-11 Pin 4 - Ground
- RJ-11 Pin 5 - test set Transmit Data

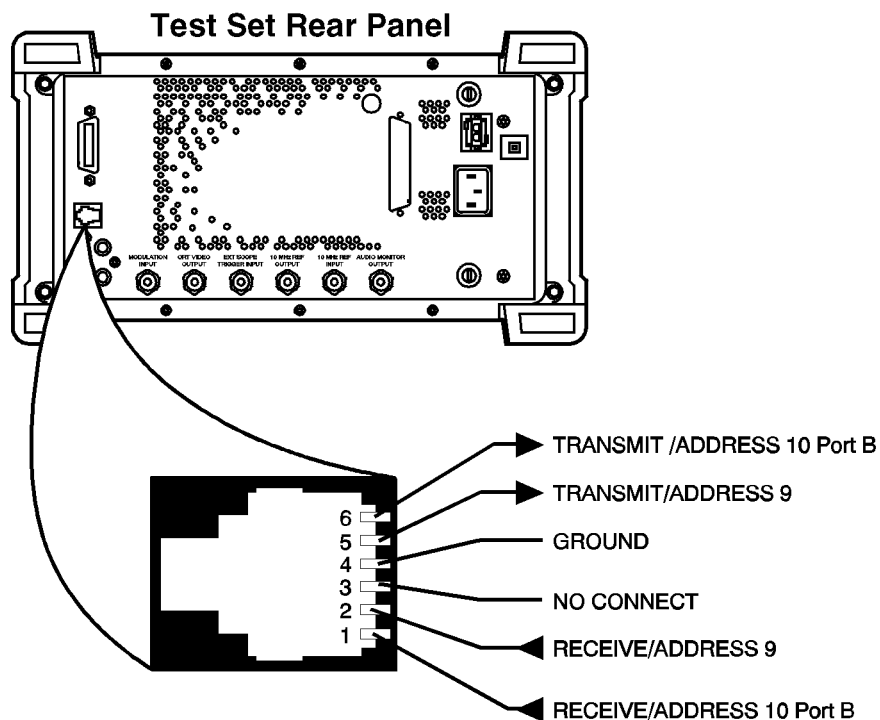

Figure 1 Test Set RJ-11 Serial Port Connections

Parallel Connection

A parallel printer can be attached to the parallel port. Use the following **figure 2** for pin information.

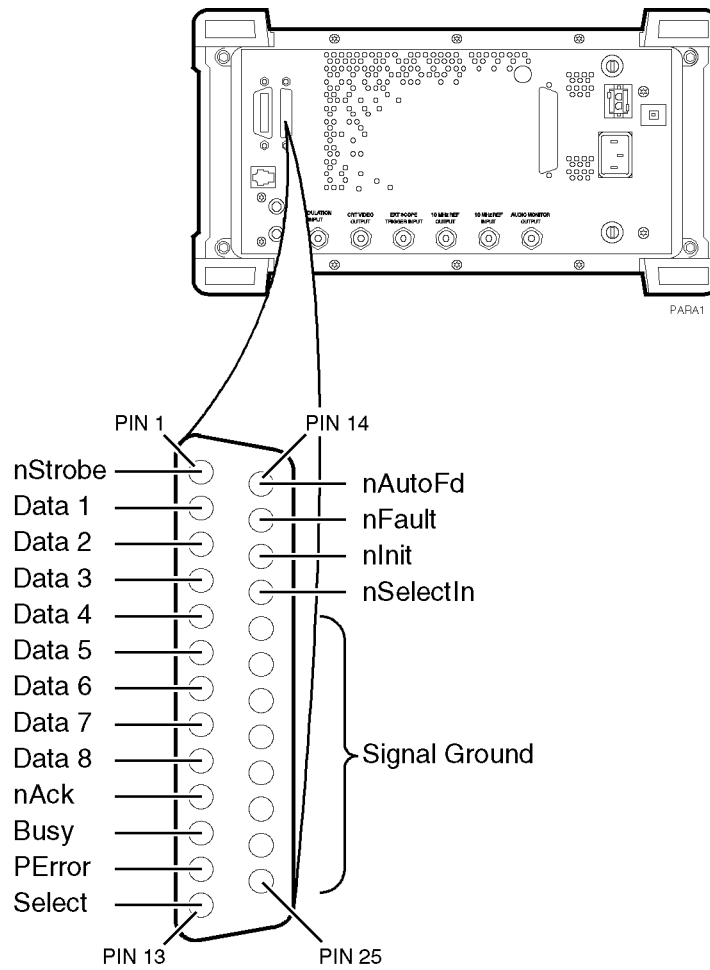

Figure 2 Test Set Parallel Port Connections

Configuring the Test Set for Printing

If using a serial printer, you cannot use the serial port for other connections at the same time, such as Data Collection (saving test results). Serial port connections are shown earlier in this section.

NOTE:

Printer Setup Differences

The HP 8920A,D had several firmware enhancements, which are standard in the HP 8920B. The following **Setup Printer** section applies to users with:

- HP 8920A,D test sets with firmware above revision A.14.00.
- All HP 8920B test sets.

The test set's firmware revision is displayed on the top right corner of the CONFIGURATION screen.

- Press SHIFT CONFIG to display the CONFIGURATION screen and read the firmware revision.

If you have an HP 8920A with firmware revision below A.14.00, refer to the next section, titled "[To Setup Printer Using HP 8920A FW Below Rev A.14.00](#)" on [page 211](#). Contact Hewlett-Packard at 1-800-922-8920 for details on upgrading your firmware if desired. EXCEPTION: If you are using A.xx.xx revision software, you can not use the **Printer Setup** screen regardless of your firmware revision. Refer to the instructions for firmware below A.14.00.

To Setup Printer Using Any HP 8920B Or HP 8920A FW Above Rev A.14.00

1. Press TESTS
2. Select **Printer Setup** from the **SET UP TEST SET** list.
3. Position the cursor to **Model** and select the desired printer.
4. Position the cursor to **Print Port** and select the desired port.
5. (If HP-IB only) Position the cursor to **Printer Adrs** and enter the HP-IB address for your printer (0-30).
6. Set the following options if desired:
 - a. Lines/Page (controls the number of lines, 20-120, printed on a page before a form feed is sent to the printer)
 - b. FF at Start (to cause a form feed at the start of a test sequence)
 - c. FF at End (to cause a form feed at the end of a test sequence)
7. From the **To Screen** menu, select **More**.
8. From the **Choices** menu, select **IO CONFIG**.
 - a. For Serial Printing, set the **Serial Baud** field and other serial communications fields listed under it to correspond to your printer's configuration.
 - b. For HP-IB Printing, set the **Mode** field to **Control**.
9. Press TESTS to return to the TESTS (Main Menu) screen.

To print test results:

1. Press TESTS
2. Select **Printer Setup** from the **SET UP TEST SET** list.
3. Position the cursor to **Output Results To** and select **Printer**.
4. Position the cursor to **Output Results For** and select **All** if you want all results printed, or **Failures** if you want failures only printed.
5. (Optional) Position the cursor to **Output Heading** and enter your desired heading.

To send Escape Sequences to the printer

If you have revision B.xx.xx software, you may use the test set to send escape sequences to control printer options such as pitch, margins, paper size, and so forth. The software comes with some pre-defined escape sequences compatible with HP printers, listed below, or you have the option to enter others which are compatible with your printer (use your printer's user's manual for the available print features and corresponding escape sequences). This function is not available with revision A.xx.xx software.

The software already has an implied escape character for the first sequence, you need only to enter the escape sequence following the escape character. However, if you are linking two or more sequences together, you must use the ~ to indicate the escape character between each sequence. If the sequence exceeds the space allotted in the options field, you may continue with additional escape sequences in the next available **Options** field. You must however, still enter **Escape Seq** in the **Calling Name** field and the appropriate address in the **Addr** field for all subsequent entries.

**How to send an
Escape Sequence:**

1. Press TESTS.
2. Select **External Devices** from the **SET UP TEST SET** list.
3. Position the cursor to the **Inst#** field and select it.
4. Rotate the knob until an empty **Calling Name** field appears, and select it.
5. Position the cursor to the **Calling Name** field and select it.
6. Select **Escape Seq** from the **Choices** menu.
7. Position the cursor to the **Addr** (address) field and select it.
8. Using the DATA keypad, enter **9** for serial printers, **15** for parallel printers, or **70X** for HP-IB printers, then press ENTER. .
9. Position the cursor to the **Options** field (directly under **Calling Name**) and select it.
10. Select the desired escape sequence from the **Choices** menu if applicable, or enter an appropriate sequence using the list of characters below the choices.

Table 14 **Escape Sequence Definitions for HP Printers**

Escape Sequence	Print Feature
&l66P	Sets page length to 66 lines
&l72P	Sets page length to 72 lines
&l6D	Sets lines per inch to 6 lines
&l8D	Sets lines to inch to 8 lines
(s12h12v6T	Selects 12 characters per inch 12/72 inch character height gothic typeface
&a9L~&l6E	Sets left margin to 9 characters top margin to 6 lines
(s12h12v6T~&a9L~&l6E	Selects 12 characters per inch 12/72 inch character height gothic typeface left margin to 9 characters top margin to 6 lines
&l8d88P	Selects 8 lines per inch 88 lines per page
&l8d96P	Selects 8 lines per inch 96 lines per page
(s16.67h12V~&a17L~&l6E	Selects 16.67 characters per inch 12/72 inch character height left margin to 17 characters top margin to 6 lines

To print TESTS screens:

TESTS screens include:

- "External Devices"
- "Order of Tests"
- "Channel Information"
- "Pass/Fail Limits"
- "Test Parameters"

The same general process is used to print the information for all of the above TESTS screens.

1. Make sure that your printer is properly connected and configured as explained earlier in this section.
2. Press TESTS.
3. Select the **CUSTOMIZE TEST PROCEDURE** screen of your choice.
4. Press k3 (**Print All**) and select it.
5. Press TESTS to return to the TESTS (Main Menu) screen.

To Setup Printer Using HP 8920A FW Below Rev A.14.00

1. Press TESTS
2. Select **Edit Cnfg** from the **Test Function** field.
3. Position the cursor to the **Inst#** field and select it.
4. Rotate the knob until an empty **Calling Name** field appears, and select it.
5. Position the cursor to the **Calling Name** field and select it.
6. Using the list of characters in the **Choices** menu, enter the word **Printer**. Select **Done** when complete.
7. Position the cursor to the **Model** field and select it (optional).
8. Using the DATA keypad, enter the Model # and press ENTER.
9. Position the cursor to the **Addr** (address) field and select it.
10. Using the DATA keypad, enter **9** for serial printers, **15** for parallel printers, or **70X** for HP-IB printers, then press ENTER. .
11. Position the cursor to the **Options** field (directly under **Calling Name**) and select it.
12. Using the list of characters from the **Choices** menu, the following commands may be entered. Separate the commands with commas (example; **LN=60 , START , END**)
 - **LN** equals the number of printed lines per page.
 - **START** causes a form feed at the start of each printout.
 - **END** causes a form feed at the end of each printout.
13. From the **To Screen** menu, select **More**.
14. From the **Choices** menu, select **IO CONFIG**.
15. For Serial Printers:
 - a. Set the **Serial Baud** field and other serial communications fields listed under it to correspond to your printer's configuration.
16. For HP-IB Printers:
 - a. Position the cursor to the **Mode** field and select it.
 - b. From the **Choices** menu, select **Control**.
 - c. Position the cursor to the **Print Adrs** field and select it.
 - d. Rotate the knob and select the HP-IB address of your printer.
 - e. Position the cursor to the **Print To** field. Pressing knob will toggle the underlined selection. Select to underline **HP-IB**.
17. Press TESTS to return to the TESTS screen.

To print test results

1. Make sure that your printer is properly connected and configured as explained earlier in this section.
2. Press TESTS.
3. Position the cursor to the **Output Results To:** field (or the **Output Destination** field). Pressing knob will toggle the underlined selection. Select to underline **Printer**.
4. Position the cursor to the **Output Heading** field and select it.
5. Using the list of characters in the **Choices** menu, enter a printout heading (optional). Select **Done** when the heading is complete.

To send Escape Sequences to the printer

If you have revision B.xx.xx software, you may use the test set to send escape sequences to control printer options such as pitch, margins, paper size, and so forth. You may enter sequences which are compatible with your printer (use your printer's user's manual for the available print features and corresponding escape sequences). This function is not available with revision A.xx.xx software.

The software already has an implied escape character for the first sequence, you need only to enter the escape sequence following the escape character. However, if you are linking two or more sequences together, you must use the ~ to indicate the escape character between each sequence. If the sequence exceeds the space allotted in the options field, you may continue with additional escape sequences in the next available **Options** field. You must however, still enter **Escape Seq** in the **Calling Name** field and the appropriate address in the **Addr** field for all subsequent entries.

**How to send an
Escape Sequence:**

1. Press TESTS.
2. Select **Edit Cnfg** from the **Test Function** field.
3. Position the cursor to the **Inst#** field and select it.
4. Rotate the knob until an empty **Calling Name** field appears, and select it.
5. Position the cursor to the **Calling Name** field and select it.
6. Enter **ESCAPE SEQ** using the characters in the **Choices** menu. Select **Done** when you are finished.
7. Position the cursor to the **Addr** (address) field and select it.
8. Using the DATA keypad, enter **9** for serial printers, **15** for parallel printers, or **70X** for HP-IB printers, then press ENTER. .
9. Position the cursor to the **Options** field (directly under **Calling Name**) and select it.
10. Select the desired sequence using the list of characters below the choices.

Table 15 **Examples of Common Escape Sequences**

Escape Sequence	Print Feature
&l66P	Sets page length to 66 lines
&l72P	Sets page length to 72 lines
&l6D	Sets lines per inch to 6 lines
&l8D	Sets lines to inch to 8 lines
(s12h12v6T	Selects 12 characters per inch 12/72 inch character height gothic typeface
&a9L~&l6E	Sets left margin to 9 characters top margin to 6 lines
(s12h12v6T~&a9L~&l6E	Selects 12 characters per inch 12/72 inch character height gothic typeface left margin to 9 characters top margin to 6 lines
&l8d88P	Selects 8 lines per inch 88 lines per page
&l8d96P	Selects 8 lines per inch 96 lines per page
(s16.67h12V~&a17L~&l6E	Selects 16.67 characters per inch 12/72 inch character height left margin to 17 characters top margin to 6 lines

To print TESTS screens

TESTS screens include:

- "Edit Cnfg"
- "Edit Seqn"
- "Edit Freq"
- "Edit Spec"
- "Edit Parm"

The same general process is used to print the information for all of the above TESTS screens.

1. Make sure that your printer is properly connected and configured as explained earlier in this section.
2. Press TESTS.
3. Select the TESTS screen you desire.
4. Press k3 (**Print All**) and select it.
5. Press TESTS to return to the TESTS screen.

Procedures

A procedure is a collection of test parameters, pass/fail limits and a testing order, saved in a file that customizes the test software to a specific application. You may save the file on a memory card or disk.

You do not have to save a test sequence in a procedure. Each test can be stand-alone if desired. After you choose a procedure, you can choose which of the tests you want to run.

When you save a procedure you will only be saving test parameters, pass/fail limits and a testing order. The memory card or disk must also contain a library file. A library file contains the names of all of the test parameters, pass/fail limits and tests that are in the test software. The library you use will be the library that is supplied with your software. When you save your procedure, the library will be automatically saved on the same card or disk.

The procedure(s) supplied with your software will be listed in the **Choices:** column when you select the **Select Procedure Filename:** (or **Procedure**) field. Procedures will be displayed if your software memory card is plugged in.

Saving a Procedure

After you have set up the test software you can save the setup to an SRAM memory card, disk, or internal RAM memory by doing the following.

The memory card or disk you use must be initialized before its first use. See ["Initializing a Memory Card" on page 196](#) or ["Initializing a Disk" on page 189](#). If you are using a disk drive, you may have to enter the **External Disk Specification** into the TESTS **External Devices** screen (or **Edit Cnfg** screen). It will be used when the **Select Procedure Location:** field on the TESTS screen is **Disk**.

- To save a procedure:**
1. Press TESTS.
 2. Select **Save/Delete Procedure** from the **CUSTOMIZE TEST PROCEDURE** list (or **Proc Mngr** from the **Test Function** field).
 3. Position the cursor to the **Select Procedure Location** (or **Location**) field and select it.
 4. From the **Choices** menu, select the desired location. The media must be initialized before a file can be saved. To initialize an SRAM card (HP 8920B or HP 8920A,D firmware above revision A.14.00 only, otherwise see ["Initializing a Memory Card" on page 196](#)):
 - a. Insert card in the slot on the test set's front panel.
 - b. Press k3 (**Init Card**)
 - c. Press **Yes**. Note: this will delete any procedures or programs from memory.To initialize a RAM disk, see "Memory Cards/Mass Storage" in the *HP 8920A Programmer's Guide*.
 5. Position the cursor to the **Enter Procedure Filename** (or **Procedure**) field and select it.
 6. From the list of characters in the **Choices** menu, enter a filename. Filename must be nine characters or less. When filename is complete, position cursor to **Done** and select it. Procedure filenames that already exist on the card will appear at the top of the list of characters.
 7. If you selected **Card**, insert an initialized memory card into the slot on the test set's front-panel.
 8. Verify that the card or other media is not write-protected. See ["Memory Cards" on page 193](#).
 9. Position the cursor to the **Enter Description for New Procedure** (or **Comment for new procedure**) field and select it. From the list of characters in the **Choices** menu, enter comments. When the comments are complete, position the cursor to **Done** and select it.

10. Position the cursor to the **Procedure Library** (or **Library for new procedure**) field and select **Current** (Current underlined). The name of the Library is displayed on the TESTS screen.
11. Position the cursor to the **Code Location** (or **Program location for new procedure**) field and select it.

From the **Choices** menu, choose memory **Card, ROM, RAM** or **Disk**. When a procedure is run, the test system will look in this location for a code file if it is not resident in the Test Set's battery-backed-up memory. This location will usually be the software memory card.
12. Press k1 (**Save Proc**) (or position the cursor to the **Action** field and select **Make Procedure**). A procedure will be saved at the location you chose.

Loading a Procedure

A procedure can be loaded from storage media into the test set's battery-backed-up memory by doing the following.

- To load a procedure:**
1. Press TESTS.
 2. Position the cursor to the **Select Procedure Location** (or **Location**) field and select it.
 3. From the **Choices** menu, choose the desired location where the procedure is stored and select: **Card, ROM, RAM** or **Disk**.
 4. Position the cursor to the **Select Procedure Filename** (or **Procedure**) field and select it.
 5. From the **Choices** menu, choose the procedure file that you want to load.
 6. Read the **Description** (or **Comment**) field to ensure that the loaded procedure file is the one you want.

Deleting a Procedure

Procedures can be removed from an SRAM memory card, disk or RAM by doing the following.

To delete a Procedure:

1. Press TESTS.
2. Select **Save/Delete Procedure** from the **CUSTOMIZE TEST PROCEDURE** list (or **Proc Mngr** from the **Test Function** field).
3. Position the cursor to the **Select Procedure Location** (or **Location**) field and select it.
4. From the **Choices** menu, select the desired location.
5. Position the cursor to the **Enter Procedure Filename** (or **Procedure**) field and select it.
6. From the **Choices** menu, select the name of the procedure you wish to delete.
7. Press k2 (**Del Proc**) (or position the cursor to the **Action** field and select **Delete Procedure**).
8. Press Yes if you wish to continue.

Securing a Procedure

After you have set up your test software with a testing order, channel information, test parameters, and pass/fail limits, you may wish to secure it. This operation will prevent the viewing and changing of those functions. You can select the items you wish to secure or un-secure. An IBASIC ROM program is stored in the Test Set's firmware to do this.

You can secure the procedure that is supplied with the test software. It is shipped un-secured.

After you make a procedure, you can secure it.

To secure a Procedure:

1. Press TESTS.
2. Position the cursor to the **Select Procedure Location** (or **Location**) field and select it.
3. From the **Choices** menu, select **ROM**.
4. Position the cursor to the **Select Procedure Filename** (or **Procedure**) field and select it.
5. From the **Choices** menu, select **IB_UTIL** (or **SECURE_IT**).
6. Press k1 (**Run Test**).
7. Select the location of the procedure you want to secure: k1 memory (**Card**) or k2 (**RAM**).

NOTE:

RAM refers to the RAM Disk memory within the test set. Before selecting RAM, you must initialize the RAM as a disk. See "[Initializing RAM Disks](#)" on page 223.

8. Proceed with the on-line instructions. You may wish to secure only one of the items, such as pass/fail limits.
9. When you are prompted to enter the **pass number**, enter any sequence of numerals 0 through 9 using the DATA keypad. Enter 9 digits or less.

To un-secure a procedure:

To un-secure a procedure, you must know the **pass number**.

1. Press TESTS.
2. Position the cursor to the **Select Procedure Location** (or **Location**) field and select it.
3. From the **Choices** menu, select **ROM**.
4. Position the cursor to the **Select Procedure Filename** (or **Procedure**) field and select it.
5. From the **Choices** menu, select **IB_UTIL** (or **SECURE_IT**).
6. Press k1 (**Run Test**).
7. Select the location of the procedure you want to un-secure: k1 memory (**Card**) or k2 (**RAM**).
8. Enter the name of the procedure you wish to un-secure.
9. If the procedure has any item secured, you will be asked for the **pass number**.
10. Proceed with the on-line instructions. Select the items you wish to un-secure.
11. When you are prompted, enter the **pass number** using the DATA keypad.

RAM

RAM disk is a section of internal memory that acts much like a flexible disk. Programs can be stored, re-stored, erased, and retrieved.

The RAM disk is partitioned into four separate volumes; 0-3. Each volume is treated as a separate 'disk'. You can also specify the size of each disk in 256-byte increments.

The four RAM disk volumes are designated **:MEMORY, 0, 0** to **:MEMORY, 0, 3**. For example, to catalogue the contents of RAM disk volume '0' from the IBASIC Cntrl screen, enter

```
CAT " :MEMORY, 0, 0 "
```

Volume 0's contents can be viewed and loaded from the three screens mentioned at the beginning of this section. Volumes 1, 2, and 3 can *only* be accessed from the IBASIC Controller.

NOTE:

RAM Disk Erasure

Any existing programs or formatting on RAM is erased if you use the **RAM_MNG** or **COPY_PL** ROM programs, or the SERVICE screen's **RAM Initialize** function.

Therefore, you should only use RAM disks for short-term storage of files.

Initializing RAM Disks

Each RAM disk volume must be initialized before it can be used. Volume 0 can be initialized using the RAM_MNG procedure stored on the internal ROM's **IB_UTIL** menu. Volumes 1, 2, and 3 must be initialized from the **IBASIC Cntrl** screen.

The optional 'volume size' in the following procedure lets you specify the memory area set aside for each disk in 256 byte blocks.

Follow these steps to initialize volumes 1, 2, or 3:

1. Press **TESTS**.
2. Select **IBASIC Cntrl** from the **SET UP TEST SET** list.
3. Position the cursor to the data entry field and select it.
4. Using the list of characters from the **Choices** menu, enter the following command:

```
INITIALIZE ":MEMORY,0,<volume number 1-3>",<volume size>
           or
INITIALIZE ":MEMORY,0,1",50
```

Saving Tests Results

See "[Data Collection \(Saving and Retrieving Test Results\)](#)" on page 179.

Serial Port

This 6-pin, RJ-11 serial port is used to input and output serial data. Serial data is used for entering programs, printing, and for sending test results to a connected controller, disk drive, or terminal.

Operating Considerations

The serial communications settings are defined on the I/O CONFIGURE screen. Ground is used with both IBASIC and all other serial connections. Transmit B and Receive B are exclusively used with IBASIC programs. Transmit and Receive are used with all other serial connections (see [figure 3 on page 226](#)).

The IBASIC Controller sends data to and receives data from the serial ports using address **9** for the primary port, and address **10** for Port B.

Use an RJ-11/25-pin RS-232 adapter (HP P/N 98642-66508) and RJ-11 cable (HP P/N 98642-66505) to connect the HP 8920A,B,D to a serial printer or terminal/computer.

NOTE:

RJ-11 Connectors

RJ-11 cables and adapters can be wired several ways. If you buy a cable or adapter other than the HP parts listed, verify the connections for the pins indicated in the following [table 16](#) before connecting cables to the instruments.

The following [table 16](#) lists connections for Transmit, Receive, and Ground pins (address 9).

Table 16 Connections for Transmit, Receive, and Ground Pins

HP 8920A/D RJ-11 Serial Port		Terminal/PC 25-Pin RS-232		Terminal/PC 9-Pin RS-232
Pin 2 (RX)	to	pin 2 (TX)	or	pin 3 (TX)
Pin 5 (TX)	to	pin 3 (RX)	or	pin 2 (RX)
Pin 4 (GND)	to	pin 7 (GND)	or	pin 5 (GND)

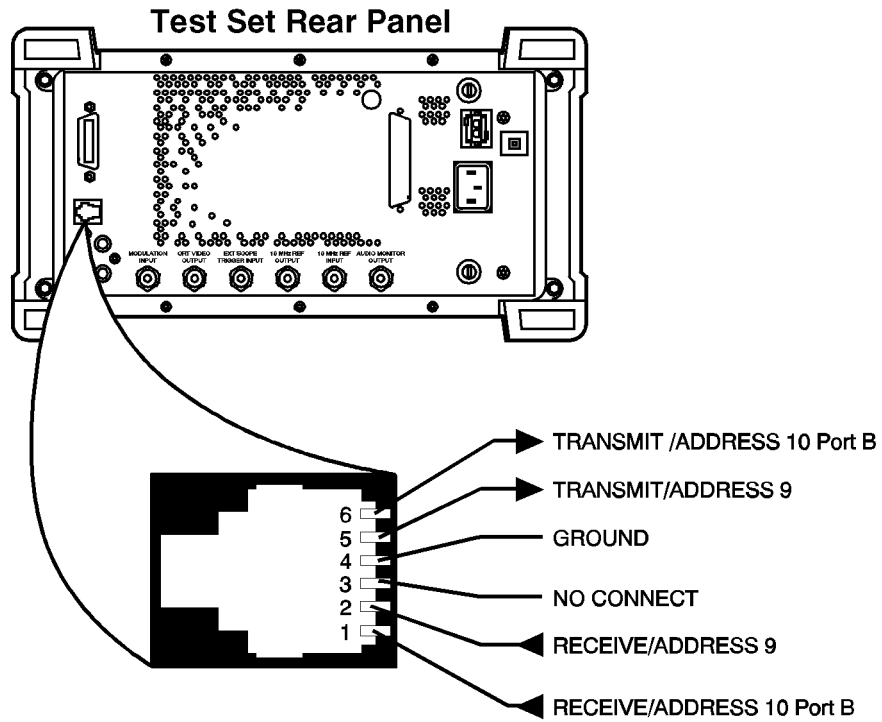

Figure 3 Test Set RJ-11 Serial Port Connections

Test Execution Conditions

In some situations, you may wish to change the way the software works when a test result is obtained. **Test Execution Conditions** allow you to do this.

Test Execution Conditions are accessed from the **SET UP TEST SET** list on the TESTS (Main Menu) screen. Press TESTS, then select **Execution Cond** to display them. (They are displayed directly on the main TESTS screen in firmware below revision A.14.00).

Test Execution Conditions are not retained after a power-down/power-up cycle.

The following **Test Execution Conditions** can be set as needed:

Output Results To: (Output Destination)

You can select either: **Crt** or **Printer** Default:**Crt**

You can specify where test results are to be placed. If you select **Crt**, results will be displayed on the test set's CRT. If you select **Printer**, test results will be sent to the CRT and to a printer. You must connect and configure a printer if you select **Printer**. See "[Printing](#)" on page 203.

Output Results For: (Output Results)

You can select either: **All** or **Failures** Default:**All**

You can specify if you want only the failed results to be displayed or printed. This will be useful if you generally do not print test results, and want to ensure that failed results are displayed or printed.

Output Heading

You can use this field to enter a heading that will be printed or displayed.

Select the **Output Heading** field. Use the knob to choose and enter the characters that you want to appear in the heading.

Choose **Done** when you are finished.

If Unit-Under-Test Fails (If UUT Fails)

You can select either: **Continue** or **Stop** Default:**Continue**

If you set this to **Stop**, and a pass/fail result is **F**, the program will stop.

Test Procedure Run Mode (Run Mode)

You can select either: **Continuous** or **Single Step** Default:**Continuous**

You can make tests pause at certain times. If you set this to **Single Step**, the program will pause after a comparison is made between a test determination and the expected result. For example, tests will pause after the program compares the results to a specification. You can continue from the paused state by pressing k2 (**Continue**).

Autostart Test Procedure on Power-Up

You can select either: **On** or **Off** Default: **Off**

You can set up the test set so that if the procedure was previously loaded, the procedure will be immediately executed when the test set is powered on.

USER Keys

When you are using the test set, you will see the following USER keys assigned appear at times in the top right corner of the display. These keys are assigned to the hard keys k1 through k5. In many cases, these keys can be used as “shortcuts” instead of positioning the cursor and selecting. USER keys are sometimes referred to as softkeys.

Clr Scr clears the test set’s CRT display.

Continue continues the program after it has been paused.

Delet Stp is used to edit items in a test sequence. When you press this key, the test in the displayed sequence that has its **Step #** highlighted (inverse video) will be deleted. The tests that follow in the sequence will be scrolled up by one step.

Del Proc is used to delete the selected procedure. When you press this key, you will be prompted to verify the command by pressing Yes.

Press **Done** when you want to exit a test or have completed a task. The program will continue if there is a next test in the sequence or if there are additional program steps in the test being run.

Help provides information on how to use the current TEST screen.

Init Card is used to initialize a memory card. Before you press this key, verify that the card is inserted correctly and not in the write-protected position.

Insrt Stp is used to enter items into a test sequence. When you press this key, the test in the displayed sequence that has its **Step #** highlighted (inverse video) will be copied into a new sequence location, immediately after the highlighted one. The tests that follow in the sequence will be scrolled down by one step. This key does nothing if there are no items in the sequence. Choose a test before using this key to insert another.

Main Menu is used to return to the main TESTS screen. The same result is achieved by pressing TESTS.

Page Up\Page Down are used to quickly display items in the list when some of the items won’t fit on the screen.

Run starts an IBASIC program that has been loaded into the test set’s memory.

Run Test loads and runs the program that is called from the procedure that has been entered into the TESTS screen **Select Procedure Filename:** entry. If the program is already loaded into the test set's memory, it will be started.

Save Proc is used to save the specified procedure.

Sngl Step steps the IBASIC program one line at a time. This is different from **Continuous/Single Step** run mode. See "[Test Execution Conditions](#)" on page 227.

Stop Test pauses the test software.

Take It causes the program to accept the setting of an adjustment, and proceed with the program. The test, determining if the adjustment is within limits, is ceased.

Yes\No are pressed when answering questions displayed on the test set's CRT display.

Problem Solving

If You Have a Problem Testing Your Radio

This section contains information for solving some of the most common problems related to using the HP 11807A,E radio-test software. All problems in this section have a single obvious symptom (shown in bold typeface at the top of each page), but many possible causes (listed in order from the most probable cause to the least probable cause).

NOTE:

If the test set displays an error that states “*One or more self-tests failed*”, you have a hardware problem. In this case, refer to the test set’s *Assembly Level Repair* manual.

If the problem has to do with operating the test set, you’ll want to refer to the MESSAGE screen to list errors or operating messages that have occurred since the instrument was turned on. To do this, press the SHIFT and then the MSSG key.

Also, the *HP Instrument BASIC* manual describes any errors that happen as a result of running IBASIC programs.

If the test procedure doesn't run on test set

- Check to see that the memory card is correctly inserted into the test set.
- Check to see that a test procedure file has been loaded into the test set.

In the upper left corner of the TESTS (Main Menu) screen, a file name should be seen in the **Select Procedure** field. If the field is blank, then a test procedure file has not been loaded.

To load a test procedure file:

1. Press TESTS.
2. Position the cursor to the **Select Procedure Location** (or **Location**) field and choose **Card** from the **Choices** menu.
3. Position the cursor to the **Select Procedure Filename** (or **Procedure**) field and choose the test procedure file you want from the **Choices** menu.

- Check that you have selected k1 (**Run Test**) to start testing.
- Check the MESSAGE screen to see if an error is causing the test procedure to not run.

If you see the error message “Structures improperly matched” or “Improper context terminator”, the software program was incorrectly loaded into the test set. In this case, refer to the directions on the next page.

NOTE:

Test procedure files are not the actual code or program needed to run the tests. You'll need to load the test procedure file, then run the selected tests with the memory card containing the program code inserted in the memory card slot. The program code remains loaded in the test set until another program is loaded.

If the HP 11807A,E program was incorrectly loaded

An error message like “Structures improperly matched” or “Improper context terminator” appears. It takes 2-4 minutes to load an HP 11807A program when k1 (**Run Test**) is first pressed. It takes approximately 15 seconds to load an HP 11807E program. Thereafter, it takes only a few seconds to run.

- Were the SHIFT CANCEL keys pressed or the memory card removed while the program was loading? If this was done, you will need to clear the RAM, or load another program and then re-load the HP 11807A,E program.

To clear RAM in the test set: (*All SAVE registers are lost.*)

1. Press TESTS.
 2. Position the cursor to **Select Procedure Location** and choose **ROM** from the **Choices** menu.
 3. Position the cursor to **Select Procedure Filename** and choose **IB_UTIL** (or **COPY_PL**) from the **Choices** menu.
 4. Press k1 (**Run test**).
 5. Press k5 (**CLEAR RAM**).
 6. Press TESTS, and re-load and run the test procedure you want.
- Check to see that the test set has enough RAM memory. To see if there's enough RAM memory:
 1. Press TESTS.
 2. Position the cursor to **Select Procedure Location** and choose **ROM** from the **Choices** menu.
 3. Position the cursor to **Select Procedure Filename** and choose **LIST_OPTS** from the **Choices** menu.
 4. Press k1 (**Run Test**).
 5. If the screen displays **OPTIONAL RAM**, your test set has enough RAM memory. If **OPTIONAL RAM** is not displayed, refer to "[Ordering Upgrades](#)" in [chapter 1, on page 17](#).

If the printer does not print the test results

- Check that the printer is turned on.
- Check that the HP-IB, parallel, or serial cable from the test set to the printer is connected.

If have firmware below revision A.14.00 OR you are using software with Revision A.xx.xx

1. Press TESTS.
2. Check that **Printer** was selected as the **Output Destination** in the **Test Execution Conditions**.
3. Check that the test set is correctly configured for HP-IB, parallel, or serial printing:

For a HP-IB printer:

- a. Check that the printer's **Calling Name** is "PRINTER" and its address is correctly set up in the **External Devices** (or **Edit Cnfg**) screen.
- b. Check that the **I/O CONFIGURE** screen has been set up correctly:
 - i. Mode=Control
 - ii. Print To=HP-IB
 - iii. Print Adrs=address of your printer

For a parallel printer:

- a. Check that the printer's **Calling Name** is **PRINTER** and its address is set to **15** in the **External Devices** (or **Edit Cnfg**) screen.

For a serial printer:

- a. Check that the printer's **Calling Name** is **PRINTER** and its address is set to **9** in the **External Devices** (or **Edit Cnfg**) screen.
- b. Check that the **I/O CONFIGURE** screen has been set up correctly for the printer's baud rate, parity, and so forth.

Refer to the test set's *User's Guide* for details about configuring the printer.

**If you have an HP 8920B or HP 8920A,D with firmware above revision A.14.00
AND you are using software with Revision B.xx.xx**

1. Press TESTS.
2. Select **Printer Setup** from the **SET UP TEST SET** list.
3. Check that **Printer** was selected in the **Output Results To:**.
4. Check that the test set is correctly configured for HP-IB or serial printing:
 - a. Select **Model** and choose the most compatible printer model from the **Choices** menu.
 - b. Select **Printer Port** and choose which printer port you are using.
 - c. If the HP-IB port was selected, check that the correct **Printer Adrs** was entered.
 - d. If the Serial port was selected, check that the I/O CONFIGURE screen has been set up correctly for the printer's baud rate, parity, and so forth.

Refer to the test set's *User's Guide* for details about configuring the printer.

If the PM radio fails the audio tests

- Check the specifications for the PM radio to make sure they match with those entered in the software Pass/Fail Limits.
- Check the audio connections from the PM radio to the test set. Refer to "**Making a Connection**" in chapter 2, on page 27 for a diagram showing the correct connections.
- Check the PM radio to make sure the microphone is not active and picking up ambient noise.
- Check the PM radio to see if the audio lines carry other signals.

For example, if the audio lines carry other dc signals, a blocking capacitor in series with the test set is required.

If radio volume can't be set on the test set's meter screen

- Check that the meter needle on the test set's meter screen moves when you turn the radio's volume knob. If the meter needle doesn't move make sure the radio is powered on.
- Check that the radio is correctly connected to the test set. Refer to "**Making a Connection**" in chapter 2, on page 27 for a diagram showing the correct connections.
- If the meter needle moves but cannot be set high enough, check to see if the parameters for setting radio volume are correctly set up. Incorrect settings for any one of these parameters will affect how the test runs.
 1. Parameter **Parameter 15. RX Audio Load Impedance** is used by the software whenever radio volume or squelch control is adjusted during testing.
 2. Parameter **Parameter 18. RX Nominal Audio Power** sets the full-scale volume level of the meter displayed on the test set. The value you enter for this parameter is scaled up by 50%.
 3. Parameter **Parameter 22. RX Tolerance For Setting Volume** sets the tolerance window displayed on the meter screen.

If your radio fails CTCSS/CDCSS tests or the tests don't run

- ❑ Check the test parameters for setting CTCSS/CDCSS squelch to be sure they are correctly set up. Incorrect settings for any one of these test parameters will affect how the test runs.
 1. Parameter **Parameter 16. RX CT/CDCSS Available/Control** lets the test set know whether the receiver's audio-squelch circuitry uses Continuous-Tone-Controlled Squelch System (CTCSS) or Continuous Digital-Controlled-Squelch-System (CDCSS) and whether CTCSS/CDCSS can be turned on and off during testing.
 2. Parameter **Parameter 17. RX CT/CDCSS Deviation** sets the amount of deviation on the signal modulating the CTCSS tone or CDCSS code word which is input to the receiver's antenna during the CT/CDCSS opening test.
 3. Parameter **Parameter 28. TX CT/CDCSS Available** lets the test set know that the radio transmits a carrier modulated with a CTCSS tone or CDCSS code word.
 4. Parameter **Parameter 29. TX CTCSS/CDCSS Control** allows the transmitted CTCSS tone code or CDCSS code word to be controlled by the test operator (that is, turned on and off).
 5. Parameter **Parameter 30. TX CT/CDCSS Filter 1 Opt** allows the CD/CTCSS filter (test set Option 010 400 Hz High-Pass Filter) to be used by the test set *if one is installed*.
- ❑ Check the **Channel Information** menu to see if the CTCSS frequency or tone code, or CDCSS code word is set up in the appropriate columns.
 1. Enter a CTCSS frequency, for example, 91.5 Hz as "**CT FR91.5**" in both RX and TX channel information columns, or
 2. Enter a CTCSS tone code, for example, "ZZ" for 91.5 Hz as "**CT ZZ**" in both RX and TX channel information columns. The tone codes supported by the software are shown in **table 17, "CTCSS Tone Codes"**, or
 3. Enter a CDCSS code word, for example "023" (octal) in both RX and TX channel information columns. The code words supported by the software are shown in the **table 18, "CDCSS Code Words"**.

Table 17 **CTCSS Tone Codes**

Tone Code	Frequency (Hz)		Tone Code	Frequency (Hz)
XZ	67		3B	131.8
—	69.3		4Z	136.5
XA	71.9		4A	141.3
WA	74.4		4B	146.2
XB	77		5Z	151.4
SP	79.7		5A	156.7
YZ	82.5		5B	162.2
YA	85.4		6Z	167.9
UB	88.5		6A	173.8
ZZ	91.5		6B	179.9
ZA	94.8		7Z	186.2
ZB	97.4		7A	192.8
1Z	100		M1	203.5
1A	103.5		M2	210.7
1B	107.2		M3	218.1
2Z	110.9		M4	225.7
2A	114.8		—	233.6
2B	118.8		—	241.8
3Z	123		—	250.3
3A	127.3			

Table 18 CDCSS Code Words

Octal Code	Octal Code	Octal Code	Octal Code
023	315	143	532
025	331	152	546
026	343	155	565
031	346	156	606
032	351	162	612
043	364	165	624
047	365	172	627
051	371	174	631
054	411	205	632
065	412	223	654
071	413	226	662
072	423	243	664
073	431	244	703
074	432	245	712
114	445	251	723
115	464	261	731
116	465	263	732
125	466	265	734
131	503	271	743
132	506	306	754
134	516	311	

If you can't get the data-collection function to work

- Check that you have **DATA C** entered in the TESTS (**External Devices**) (or **Edit Config**) menu.
 1. Press TESTS.
 2. Select the **External Devices** screen, from the **SET UP TEST SET** list (or **Edit Config** from the **Test Function** field).
 3. Position the cursor to the **Calling Name** field, push the knob and enter:
DATA C.
- Check the **Model** field, it should be kept empty since it is not used.
- Check the **Addr** (address) field to make sure the correct address is entered for where the data is to be stored.
 1. If data is to be stored on an SRAM memory card, enter “1” into the **Addr** field.
 2. If data is to be stored on an external computer through the test set's RS-232 serial port (if available), enter “9” into the **Addr** field.
 3. If data is to be stored on an external disk drive over HP-IB, enter an address of “700” or greater into the **Addr** field.
- Check the **Options** field to make sure it is correctly set up:
 1. **For an external disk drive (LIF format) or an SRAM memory card:**
 - a. Enter **ASCII** for saving data as an ASCII file.
 - b. Enter **BDAT** for saving data as a Binary-Data file.
 - c. As an option, you may enter **REC=xxx**, where “xxx” is the number of records for each file. *(The software defaults to 80 records. However, if too small a record size is used, you'll get an “End of file error” when the test is run.)*
 2. **For a DOS disk drive, you may keep the Options field empty, or you may enter any of the following key words:**
 - a. Enter **ASCII** for saving data as an ASCII file.
 - b. Enter **BDAT** for saving data as a Binary-Data file.
 - c. Enter **REC=xxx** for the file's record size, where “xxx” is the number of records for each file. *(The software defaults to 80 records. However, DOS systems automatically change record size if it's too small.)*
 - d. Enter a (**dot extension**) of 3 characters or less for the file name. For example, all model ABCD radio's tested may be organized to have a “.ABC” file extension.

- Check the test set to make sure it's in the controller mode *if you are using an external disk drive*.
 1. Access the I/O CONFIGURE screen from the **More** field in the **To Screen** menu.
 2. Position the cursor to the **Mode** field and select **Control**.

NOTE:

When the test operator is prompted to enter a file name where data is to be stored, the protocol for the mass-storage device being used must be followed.

Hierarchical directory paths are not allowed, and all files are created with "FORMAT ON".

Also, when initializing a disk, use the following format ("7xx" is the disk address, "y" is the device selector):

DOS disk: INITIALIZE "DOS:CS80,7xx,y"

LIF disk: INITIALIZE ":,7xx,y"

Glossary

CANCEL A key used to pause (stop) the IBASIC program running in the test set.

card Refers to the memory card containing the procedures for testing the unit-under-test.

Choices Refers to a field in the lower right of the screen that displays several possible functions for selection.

Continue Proceed with the IBASIC software program if it has been stopped (paused).

CS Carrier Squelch

CTCSS Continuous Tone Controlled Squelch System

cursor Refers to the brightened region of the screen used to indicate the field/function currently being accessed.

Del Step A function to delete a step in the procedure.

Disp Loc A menu function which presents an assembly diagram that displays location of the adjustable component.

ESD ElectroStatic Discharge - A transfer of electric charge from one place to another. Devices can be damaged by the energy transferred during the discharge.

field An area on the CRT with an inverse video display (**example**) where entries can be made.

function Refers to a particular field, feature, or operation of the test set.

Help (Help) from any TEST screen. Note: this feature is only available in the HP 8920B or HP 8920A,D firmware above revision A.14.00.

HELP A feature providing additional test set information accessed by pressing SHIFT, then TX (HELP) keys. Help topics are listed in alphabetical order.

highlight Refers to the brightened region (cursor) of the screen used to indicate the field/function currently being accessed.

HPF High- Pass-Filter. A filter that increasingly passes signals as their frequency increases towards, and then is greater than, a certain cutoff frequency. In the test set, audio high pass filters are used to reduce the level of low frequency signals during certain measurements.

IBASIC Instrument BASIC is the computer language (code or software) used by the test set's built-in controller. The IBASIC software is downloaded from the OTP CARD into the test set's RAM. This software is then used to control the test set during autotesting the unit-under-test.

initialize A card or disk must be formatted prior to storing data. This may be done by pressing k3 (**Init Card**) on the TESTS (**Save/Delete Procedure**) screen. The default for PCMCIA cards (HP 11807E) is DOS format, and for Epson Cards (HP 11807A/B) is LIF format. See "**Memory Cards**" in chapter 5 on page 193 for information on changing these default settings.

Glossary

key (USER keys) Keys refer to any of the push buttons on the front panel of the test set. The USER keys are a specific grouping of keys labeled k1 to k5 which perform the associated numbered function in the action field located in the upper right of the screen. The USER keys are user programmable.

knob The large tuning dial for cursor control located in the center of the test set front panel. This knob is rotated to position the cursor on the screen and then pressed to select the particular field or function.

library A collection of the names of all of the parameters, pass/fail limits, and tests in the test software. The test software and the test set's firmware use the library, test software program code file, and a procedure to run a customized application program. A library is stored as a file on a memory card or other mass storage with its associated procedure files.

Location Where to retrieve or save a particular testing procedure, for example, to a disk, card, RAM, or PC.

LPF Low-Pass Filter. A filter that increasingly rejects signals as their frequency increases towards, and then is greater than, a certain cutoff frequency. In the test set, audio low-pass filters are used to reduce the level of high frequency signals during certain measurements.

measurement A series of calculations on data measured by the test set. These calculations provide a value to be compared against pass/fail limit values that verify the performance of the unit-under-test.

Main Menu The screen accessed by

pressing the TESTS key, or k5 (**Main Menu**). It is used to customize and execute (run) automated testing.

Also referred to as the "TESTS" screen.

menu The test set's screen displays various tasks to be selected with the cursor control knob or the USER keys ; this display is the menu.

message The upper portion of the test set's screen is reserved for messages and prompts. Messages give an indication of the status of the test set, for example, **System initialization**.

OTP One Time Programmable (OTP) refers to a CARD on which code or data may only be stored once; similar to ROM. The HP 11807A/E software is shipped on an OTP memory card.

parameters Entries you make for calibration data, radio characteristics, or test customization. They give you flexibility in the way you use the software. Default values for parameters are present in the software.

pass/fail limits Pass/fail limits are the names of criteria verifying the performance of the unit-under-test. Usually, the associated measurement value must fall within the HI/LO limits of pass/fail values to verify performance of the unit-under-test. Default values in the test software have been derived from standard methods of measurement or from the unit-under-test requirements.

Glossary

pause Using the CANCEL key pauses the running of IBASIC software in the test set and allows access to the keyboard functions. CONTINUE allows the software to proceed.

peak+/- max A detector in the test set that measures and computes the maximum of the absolute value of the positive and negative excursions of the measurement. For example, when an FM waveform with a +10 kHz and -9 kHz deviation is applied, 10 kHz will be displayed.

PRESET Sets the test set to its initial power-up state.

procedure A shortened label for test procedure. A procedure is a collection of channels, parameters, pass/fail limits, and testing order, saved in a file, that customizes the test software to a specific application. Procedures are made by editing existing channels, parameters, pass/fail limits, and testing order, and saving the resulting files to a memory card, disk or internal test set RAM.

prompts The upper portion of the test set (inverse video field) is reserved for prompts and messages. The prompt directs the user to take some action. Messages give an indication of the status of the test set.

RAM Random Access Memory - The memory in the test set that is used to store program code and data. The test set's RAM is battery-backed-up, retaining data and program codes when the power is turned off.

ROM Read Only Memory

Run Test Directs the test set to load the program from the current procedure and begin testing (may take up to two minutes).

save Save and store are used synonymously and refer to putting data or software on some memory device, such as, card or RAM.

screen Refers to the video display of the test set.

select To choose a particular field or function. Rotate the CURSOR CONTROL knob and position the highlighted cursor on the chosen field or function, then press the knob. An alternative method is to press the numbered USER key having the same number as displayed alongside the desired function.

SINAD Signal plus noise and distortion divided by noise and distortion. A measurement result that determines the quality of an audio tone in the presence of noise and distortion. A 12 dB SINAD value is often used when measuring a receiver's sensitivity.

softkey The name of the set of keys next to the CRT display that can be assigned to certain special actions or fields. The keys are also called USER keys.

SRAM Static Random Access Memory - A data storage device. SRAM memory cards can be used with the test set to save programs and test results.

Step# Orders the sequence of tests, e.g. Step #1 may be Test_5, and Step #2 may be Test_26 and so on.

Glossary

store Store and save are used synonymously and refer to putting data or software on some memory device, such as card, RAM.

tests Tests are a collection of measurements (or a series of other tests) which verify a particular specification value or operation of the UUT. A sequence of tests are contained in a test procedure.

TESTS screen The screen accessed by pressing the TESTS key. It is used to customize and execute (run) all automated testing. Also referred to as the “Main Menu”.

USER keys A group of keys located immediately to the right of the test set’s screen that allow the user to more rapidly select certain functions without rotating and pressing the knob. These key assignments are displayed in the upper right portion of the test set’s screen. The number on the left of the function corresponds to the number on the user key k1 to k5.

values The scalar quantities or numbers inserted in the inverse video fields of the pass/fail limits or parameters. Units of measure (dB, inches, volts, watts, etc.) are contained in the pass/fail limits and test parameters.

Numerics

1-800 help line, [19](#)
400 Hz HPF filter, [17](#)

A

additional services available, [19](#)
adjust volume, [127](#)
AdvanceLink, [184](#)
AF analyzer
 CCITT filter option, [136](#)
 de-emphasis, [137](#)
AM current
 from power supply, [91](#)
amplitude characteristics
 RF levels 1 and 2, [120](#)
amplitude characteristics test
 for the receiver, [105](#)
ASCII file type, [179](#)
attenuator loss, [17](#), [114](#)
audio band
 frequency deviation test parameter, [139](#)
audio distortion, [164](#)
 receiver pass/fail limit, [147](#)
 RF levels 1 and 2, [121](#)
 test parameters, [121](#)
 transmitter pass/fail limit, [158](#)
audio distortion test
 for the receiver, [102](#)
 for the transmitter, [97](#)
AUDIO IN connector, [123](#)
audio lines
 carry other signals, [237](#)
audio modulation index error
 transmitter pass/fail limit, [159](#)
audio power
 maximum, [130](#)
audio power, nominal
 receiver test parameter, [126](#)
audio squelch sensitivity test
 for the receiver, [106](#)
audio testing fails, [237](#)
audio-frequency level
 at the receiver output, [105](#)
audio-frequency noise, [101](#)
audio-frequency noise and hum, [151](#)
audio-frequency noise power, [99](#)
audio-frequency output level
 variations, [103](#)
audio-frequency power, [151](#)
audio-frequency response, [164](#)
 delta from 6 dB/octave, [148](#)
 of the receiver, [103](#)
 of the transmitter, [159](#)
 receiver pass/fail limit, [148](#)
 step frequency test parameter, [122](#)
 step size, [133](#)
 transmitter test parameter, [133](#)
audio-frequency response test
 for the transmitter, [96](#)
audio-level change
 for SINAD, [152](#)
audio-load impedance
 receiver test parameter, [123](#)
audio-output levels
 the difference in measured, [120](#)
audio-output power
 for the receiver, [126](#)
audio-squelch circuitry, [124](#)
audio-squelch sensitivity, [154](#), [155](#)
Autostart, [86](#)
Autostart Test Procedure on Power-Up,
 [228](#)

B

battery drain, 153
 radio specification, 162
BDAT file type, 179
blocking capacitor
 for dc signals, 237

C

cable loss
 for pads and cables, 17
 test parameter, 114
CANCEL, 202, 245
card
 how to insert, 26, 60
carrier
 modulated with a CTCSS tone, 134
carrier frequency, 92
carrier output power
 at radio's low-switch setting, 112
 test parameter, 111
carrier power
 radio specification, 167, 168, 169, 170,
 171, 172
CAT IBASIC command, 177
CCITT filter
 is installed, 136
CCITT Weighting filter, 17
CDCSS
 if your radio has, 94
CDCSS available
 transmitter test parameter, 134
CDCSS available/control
 test parameter, 124
CDCSS code word, 125, 135
 carrier modulated, 134
CDCSS code-word table, 241
CDCSS control
 transmitter test parameter, 135
CDCSS deviation
 receiver test parameter, 125
 transmitter pass/fail limit, 160
CDCSS deviation and frequency test
 for the transmitter, 100
CDCSS filter
 transmitter test parameter, 136
CDCSS opening level
 receiver pass/fail limit, 149
CDCSS opening test
 for the receiver, 107
CDCSS parameters, 239
CDCSS SINAD at opening
 receiver pass/fail limit, 150
CDCSS squelch, 97
CDCSS tests fail, 239
CEPT standards
 for PM tests, 90
Changing the Order of Tests, 32
channel information
 general description, 36
 securing, 220
channel numbers
 specifying information, 36, 70
channel separation
 transceiver test parameter, 113
channel spacing
 transceiver test parameter, 113
Choices, 176, 245
choose, 176
Clr Scr, 229
code word
 for CDCSS, 239
codes, tone
 for CTCSS, 239
code-word table
 for CDCSS octal codes, 241
configuration
 for data collection, 179
 for terminal or PC operation, 187
CONFIGURE screen
 for printer, 235
configuring an IBM-compatible PC with
 HP AdvanceLink, 184
connecting
 a printer, 204
 the radio, 26, 60
connections
 parallel printer, 205
 RJ-11 connector, 204
 serial printer, 204
Continue, 229, 245
Continue USER key, 202
continuing a paused program, 202
conventions used, 176
COPY IBASIC command, 177
COPY_PL program, 234
copying files, 177
CTCSS, 245
CTCSS available
 transmitter test parameter, 134
CTCSS available/control
 test parameter, 124
CTCSS control
 transmitter test parameter, 135

-
- CTCSS deviation
 - receiver test parameter, 125
 - transmitter pass/fail limit, 160
 - CTCSS deviation and frequency test
 - for the transmitter, 100
 - CTCSS filter
 - HP 8920A Option 010, 400 Hz HPF, 239
 - transmitter test parameter, 136
 - CTCSS frequency, 239
 - CTCSS frequency error
 - transmitter pass/fail limit, 161
 - CTCSS opening level
 - receiver pass/fail limit, 149
 - CTCSS opening test
 - for the receiver, 107
 - CTCSS parameters, 239
 - CTCSS SINAD at opening
 - receiver pass/fail limit, 150
 - CTCSS squelch
 - if the radio uses, 135
 - CTCSS tests fail, 239
 - CTCSS tone, 125
 - CTCSS tone code
 - carrier modulated with a, 134
 - to be controlled by, 135
 - CTCSS tone-code table, 240
 - current
 - required by AM radio, 91
 - current drain
 - receiver stand-by, 153
 - stand-by, 91
 - transmitter pass/fail limit, 162
 - current measurement, 17
 - current-measuring circuit, 91
 - cursor, 245
 - customizing testing, 30, 64
- D**
- data collection
 - description, 179
 - entering the configuration for, 179
 - example configuration, 180
 - memory card part numbers, 194
 - retrieving data, 182, 190, 198
 - saving to a memory card or disk, 179
 - to a PC, 184
 - to a PC, setting up, 186
 - dc current measurement connectors, 17
 - dc signals
 - require a blocking capacitor, 237
 - de-emphasis
 - 750 mu sec filter, 137
 - transmitter test parameter, 137
 - dekey between TX tests
 - transmitter test parameter, 138
 - Del Proc, 229
 - Delet Stp, 229, 245
 - deleting a procedure, 219
 - deviation
 - frequency tested >3 kHz, 140
 - full-rated system, 115
 - in excess of, 94
 - modulating the CTCSS tone, 125
 - start, step, and stop for audio band, 139
 - deviation, CT/CDCSS
 - transmitter pass/fail limit, 160
 - deviation, CTCSS/CDCSS, 100
 - deviation, frequency
 - transmitter pass/fail limit, 163
 - disk
 - initializing, 189
 - retrieving data from, 190
 - disk drive
 - External Disk Specification, 217
 - disk formats, LIF and DOS, 179
 - distortion
 - audio, 97
 - harmonic, 97
 - distortion factor, harmonic
 - in transmission, 158
 - distortion, audio, 102
 - test parameters, 121
 - testing for, 147
 - distortion, harmonic
 - test parameters, 121
 - Done, 229
 - DOS disk format, 179
 - DOS file type, 179
 - dual-power modes
 - for testing output-power error, 172
-

E

Edit Configuration
 data collection to a PC, 186
Edit Frequency, 36, 70
Edit Parameter, 46, 80
Edit Sequence, 66
Edit Spec, 201
Edit Specifications, 43, 77
enter, 176
ENTER key, 176
errors
 from hardware problems, 232
 from IBASIC, 232
 from operating HP 8920A, 232
 Improper context terminator, 234
 improper context terminator, 233
 on MESSAGE screen, 232
 Structures improperly matched, 234
 structures improperly matched, 233
escape sequences, 207
 rev B software with fw below A.14.00,
 212
ETSI standards
 for PM tests, 90
exiting a program, 191
external pad and cable loss, 114
extreme settings, test at
 test parameter, 119

F

Factory Hot Line, 19
field, 245
 selecting a, 176
file name
 disk example, 190
 DOS with extensions, 181
file types
 ASCII, 179
 BDAT, 179
 DOS, 179
 HP-UX, 179
files
 copying, 177
filter
 400 Hz HPF, 17, 136
 750 “micro”sec de-emphasis, 137
 CCITT installed, 136
 CCITT Weighting Filter, 17
 for CDCSS tests, 239
 for CTCSS tests, 239
 for CTCSS/CDCSS, 136
 HPF for TX audio distortion, 97
flash
 memory cards, 193
frequency
 editing values, 36, 70
 general description, 70
frequency deviation
 at the microphone, 98
 is measured, 94
 test parameter for, 113
 transmitter pass/fail limit, 163
 transmitter test parameter, 139
frequency deviation test
 for the transmitter, 95
frequency deviation tested
 transmitter test parameter, 140
frequency error
 transmitter pass/fail limit, 164
frequency error test
 at extreme power supply voltages, 92
 for the transmitter, 92
frequency error, CTCSS, 100
 transmitter pass/fail limit, 161
frequency information, secured, 144
frequency response
 test parameter for, 113

frequency response test
 for the receiver, 103
frequency stability, 164
frequency table
 of CTCSS tone codes, 240
front-panel control characters, 187

H

hardware configurations, 16
hardware errors, 232
harmonic components
 in audio distortion, 102
harmonic distortion, 97
 test parameters, 121
harmonic distortion factor, 147
 in transmission, 158
Help, 229
high-pass filter
 400 Hz, 17
 for CDCSS tests, 239
 for CTCSS tests, 239
 for TX audio distortion, 97
 Option 010, 136
high-power voltage setting
 test parameter, 116
high-supply voltage
 test parameter, 116
HP 8920A, Option 010, 400 Hz HPF, 239
HP-IB
 power supply, 17
HP-IB control
 of the power supply, 119
HP-IB control annunciators, 192
HP-IB printer, 206, 235
HP-IB printer connections, 204
HP-UX file type, 179
hum and noise
 pass/fail limit for, 151
hum power
 from spurious effects, 101

I

IBASIC, 245
 copying files, 177
 errors, 232
 initializing a disk, 189
 initializing RAM, 223
 retrieving data from a card, 182, 198
 retrieving data from a disk, 190
 TESTS screen, 30, 64
IBASIC commands
 entering from a terminal, 177
If Unit-Under-Test Fails, 52, 228
If UUT Fails, 228
impedance
 audio load, 123
improper context terminator
 error, 233, 234
Init Card, 229
initialized
 when the Test Set is, 118
initializing, 245
initializing a disk, 189
initializing an SRAM memory card, 196
initializing RAM disks, 223
Insrt Stp, 229

L

library, 246
 definition, 48, 82
 saving, 48, 82, 216
LIF disk format, 179
limiting, modulation, 166
loading a procedure, 218
loading software, 26, 60
Location, 29, 63, 246
low-power voltage setting
 test parameter, 117
low-supply voltage
 test parameter, 117

M

Main Menu, 229, 246
maximum battery drain, 153
measurements, 90, 246
memory cards, 245
 are used for, 193
 determining whether it is OTP, flash, or SRAM, 193
 flash, 193
 how they're powered, 193
 initializing, 196
 inserting, 193
 OTP, 16, 193
 removing, 194
 retrieving data from, 182, 198
 saving data to, 179
 software, 26, 60
 SRAM, 16, 193
 SRAM battery part number, 194
 Static Random Access Memory (SRAM), 194
 storage space needed, 195
 write protect switch, 195
MESSAGE screen errors, 232
meter needle
 for setting radio volume, 238
meter screen
 for setting radio volume, 238
 full-scale reading, 130
 percentage of error, 130
 volume level, 126
MIC/ACC connector, 143
microphone
 frequency deviation at the, 98
 not active, 237
microphone and accessory connector, 143
microphone sensitivity
 transmitter pass/fail limit, 165
 transmitter test parameter, 141
microphone sensitivity test
 for the transmitter, 98
modulation frequencies
 exceeding 3 kHz, 140
modulation frequency
 is fixed by software, 122
modulation index error, 96
 is the ratio of, 159

modulation limiting
 transmitter pass/fail limit, 166
modulation limiting test
 for the transmitter, 94
modulation, residual
 transmitter pass/fail limit, 173

N

No, 229
noise and hum
 receiver pass/fail limit, 151
noise and hum test
 for the receiver, 101
nominal (normal) power-supply voltage, 118
nominal audio power
 receiver test parameter, 126
nominal supply voltage, 93
 test parameter, 118

O

octal code table
 of CDCSS code words, 241
 offset RF frequencies, 102
 On UUT Failure, 86
 operating errors, 232
 option 010
 400 Hz HPF, 136
 Optional RAM message, 234
 order of tests
 printing, 203
 saving, 217
 ordering upgrades, 17
 OTP
 memory cards, 16, 193
 OTP card, 246
 Output Destination, 86, 227
 Output Heading, 52, 86, 227
 output impedance, 123
 output power
 at low switch, transmitter test parameter, 142
 for usable sensitivity, 152
 with the power supply set to low, 142
 output power error
 at high-power low-switch setting, 169
 at high-power setting, 168
 at low-power low-switch setting, 171
 at low-power setting, 170
 at the radio's low-switch setting, 172
 transmitter pass/fail limit, 167, 168, 169, 170, 171
 output power error test
 for the transmitter, 93
 output power, rated carrier
 at radio's low-switch setting, 112
 test parameter, 111
 Output Results, 86, 227
 For, 52, 227
 To, 52, 227

P

pad and cable loss
 test parameter, 114
 Page Down, 229
 Page Up, 229
 parallel printer connections, 205
 parameters, 246
 editing values, 46, 80, 200
 for CDCSS squelch, 239
 for CTCSS squelch, 239
 for setting radio volume, 238
 general description, 46, 80, 200
 printing, 203
 saving, 48, 82, 200, 217
 securing, 220
 part numbers
 memory card battery, 194
 SRAM Memory Cards, 194
 pass number, 220
 pass/fail limits, 246
 default values, 145
 descriptions, 145
 editing values, 43, 77, 201
 general description, 43, 77, 201
 printing, 203
 saving, 201, 217
 securing, 220
 pause, 247
 pausing a test, 202
 PC
 collecting data to, 184
 peak+ deviation
 for CTCSS/CDCSS, 100
 PM radio
 fails audio tests, 237
 fails CDCSS tests, 239
 fails CTCSS tests, 239
 parameters for setting volume, 238
 PM signal
 pre-emphasized, 137
 power error, output
 at high-power low-switch setting, 169
 at high-power setting, 168
 at low-power low-switch setting, 171
 at low-power setting, 170
 transmitter pass/fail limit, 167, 168, 169, 170, 171
 power measurements

compensate for loss, 114
 Power Requirements
 radio specification, 168, 169, 170, 171
 power settings
 for accurate, 123
 power supply, 17
 current, 91
 noise and hum from the radio's, 151
 the radio's external, 116, 117
 power supply voltage
 for extreme sensitivity measurements, 157
 nominal (normal) value, 118
 set to its low setting, 142
 power, rated carrier output
 at radio's low-switch setting, 112
 test parameter, 111
 power-supply measurements, 93
 pre-emphasis slope, 103
 pre-emphasized
 PM signal, 137
 PRESET, 26, 60, 247
 print options
 margins, 207, 212
 paper size, 207, 212
 pitch, 207, 212
 typeface, 207, 212
 printer
 does not print, 235
 HP-IB, 206
 HP-IB or serial, 235
 output heading, 227
 serial, 206
 printers supported, 203
 printing, 203
 test results, 227
 test results using firmware above revision A.14.00, 207
 test results using firmware below revision A.14.00, 212
 TESTS Screens, 210, 215
 using A.xx.xx revision software, 206
 procedure, 29, 63, 90, 247
 deleting, 219
 general description, 48, 82, 216
 loading into test set memory, 218
 names, 216
 saving, 48, 82, 217

securing, 220
un-securing, 221
what is saved, 216
program
 exiting a program, 191
 incorrectly loaded, 234
 stored in test set memory, 194
programmable power supplies, 17, 93

Q

quick test
 for the receiver, 107
 for the transmitter, 109

R

radio
 adjust the squelch control, 128
 channel security, 144
 connecting, 26, 60
 dekey between TX tests, 138
 keying, 143
 operator to de-key, 138
 security, 144
 squelch setting, 129
 transmit continuously, 138
radio power-supply voltage
 normal value, 118
radio standards
 for PM, 90
radio volume
 can't be set, 238
 control, 130
 for the receiver is set, 127
 manually setting, 130
 parameters, 238
 receiver test parameter, 127
RAM, 247
 disk, 222
 initializing, 222
 memory extension, 16
RAM memory
 enough for the test set, 234
rated carrier-output power
 at radio's low-switch setting, 112
 test parameter, 111
rated system deviation, 94
REC=
 default entry, 180
 entering record number, 180
REC= to set record size, 180
receiver
 amplitude characteristics test, 105
 amplitude characteristics test parameter, 120
 audio distortion, 102
 audio distortion pass/fail limit, 147
 audio frequency response test parameter, 122
 audio-frequency response pass/fail limit, 148
 audio-load impedance, 123
 audio-squelch sensitivity, 106

-
- CDCSS opening level pass/fail limit, 149
 - CT/CDCSS available/control test parameter, 124
 - CT/CDCSS SINAD at opening pass/fail limit, 150
 - CTCSS deviation test parameter, 125
 - CTCSS/CDCSS opening test, 107
 - current drain, 91
 - frequency response test, 103
 - frequency security, 144
 - noise and hum pass/fail limit, 151
 - noise and hum test, 101
 - nominal audio power test parameter, 126
 - quick test, 107
 - radio volume is set, 127
 - RF levels 1 and 2 test parameter, 120
 - sensitivity testing, 132
 - SINAD audio-level change at extremes, 152
 - sqelch control test parameter, 128
 - sqelch preset only, 129
 - sqelch sensitivity pass/fail limit, 154
 - stand-by current drain pass/fail limit, 153
 - tight-squelch sensitivity pass/fail limit, 155
 - tolerance for setting volume, 130
 - usable sensitivity at extremes pass/fail limit, 157
 - usable sensitivity pass/fail limit, 156
 - usable sensitivity set and measure, 131
 - usable sensitivity SINAD level, 132
 - usable sensitivity test, 104
 - receiver SINAD
 - the RF signal level required, 104
 - receiver squelch, 106
 - residual modulation
 - as a ratio of, 99
 - transmitter pass/fail limit, 173
 - residual modulation test
 - for the transmitter, 99
 - retrieving data from a memory card, 182
 - RF carrier
 - modulated with a CTCSS tone, 134
 - RF frequencies, offset, 102
 - RF generator's
 - output level, 131
 - RF input level
 - of a modulated signal, 105
 - RF levels 1 and 2
 - amplitude characteristics, 120
 - audio distortion test parameters, 121
 - RF power
 - radio specification, 167, 172
 - RF signal level
 - for audio distortion, 102
 - for receiver SINAD, 104
 - RJ-11 connectors, 225
 - rms value
 - of the complete signal, 102
 - ROM, 247
 - Run, 229
 - Run Mode, 86, 228
 - Run Test, 229, 247
 - difference between Run and, 198
 - running tests, 22
 - overview, 24, 58
- S**
- save, 247
 - SAVE IBASIC command, 177
 - Save Proc, 229
 - SAVE registers lost, 234
 - saving
 - procedure, 48, 82, 217
 - test procedure, 48
 - test results, 179
 - secure frequency information, 144
 - SECURE IT ROM program, 220
 - securing a procedure, 220
 - security
 - for the radio, 144
 - select, 176, 247
 - sensitivity
 - audio squelch, 155
 - for the microphone, 98
 - of the modulator, including microphone, 165
 - testing, 132
 - the receiver's usable, 156
 - sensitivity, microphone
 - transmitter pass/fail limit, 165
 - transmitter test parameter, 141
 - sensitivity, threshold squelch, 150
 - sensitivity, usable
 - at extreme supply voltage, 157
 - measured at extreme supply voltage, 152
 - set and measure, 131
 - sequence
 - changing, 32
 - editing, 66
 - general description, 32, 66
 - saving, 48, 82
 - Serial Port, 225
 - serial printer, 206, 235
 - serial printer connections, 204
 - setting RF level, 114
 - SINAD, 247
 - at the CTCSS/CDCSS opening level, 107
 - SINAD audio-level change
 - receiver pass/fail limit, 152
 - SINAD level
 - is within specified limits, 131
 - receiver usable sensitivity, 132
-

-
- SINAD ratio
 for usable sensitivity, 104
- Sngl Step, 229
- softkeys, 229, 247
- software
 how to load, 29, 63
 loading, 26, 60
 overview, 24, 58
 stopping the, 202
- software revision A.xx.xx
 printer setup, 206
- special display conventions used, 176
- specifications
 default values, 145
 descriptions, 145
 editing values, 43, 77
 general description, 43, 77, 201
 saving, 48, 82
- specifying channel information
 general description, 36, 70
- spurious effects
 of the radio's power supply, 99, 101
- sqelch
 CDCSS, 97, 239
 CT/CDCSS test parameter, 124
 CTCSS, 239
- sqelch control, 126
 receiver test parameter, 128
- sqelch knob, 129
- sqelch preset only
 receiver test parameter, 129
- sqelch sensitivity, 114, 126
 audio, 154, 155
 threshold, 154
 tight, 155
- sqelch setting
 software takes the, 128
 tight, 154
- sqelch tone
 opening level, 150
- SRAM, 247
 memory cards, 16, 193, 194
- standards
 for PM tests, 90
- stand-by current drain
 receiver pass/fail limit, 153
- stand-by current drain test, 91
- step size
 for audio-frequency response, 133
- Stop Test, 229
- stopping a test, 202
- stopping the program
 using Test Execution Conditions, 52, 86, 227
- structures improperly matched
 error, 233, 234
- supply voltage
 test parameter for normal value, 118
- system deviation
 test parameter, 115
- T**
- Take It, 229
- terminal emulator, 190
 configuration, 187
 DataStorm Technologies, Inc. Pro-Comm, 184
 HP AdvanceLink, 184
- TEST, 94, 98
- test at extreme settings
 test parameter, 119
- Test Execution Conditions, 52, 86, 227
- Test Function, 30, 64
 Edit Frequency, 70
 Edit Parameter, 46, 80
 Edit Sequence, 66
 Edit Specifications, 43, 77
 Procedure Manager, 48, 82
- test parameters
 default values, 110
 descriptions, 110
 editing values, 200
 general description, 200
- test procedure, 48
 saving, 217
- Test Procedure Run Mode, 52, 228
- test procedures
 don't run, 233
 to load, 233
- test results
 output failures, 227
 printing using firmware above revision A.14.00, 207
 printing using firmware below revision A.14.00, 212
 retrieving from a disk, 190
 retrieving from a memory card, 182, 198
 saving, 179
 security, 144
 where sent, 227
- Test Set
 keying the UUT, 143
- test time, 202
- testing order
 securing, 220
- tests, 248
 entering a sequence of, 32, 66
 environment and conditions, 46, 80
-

-
- pausing or stopping, 202
 - reference information, 90
 - running, 22
 - TESTS (Pass/Fail Limits) screen
 - entering into, 201
 - TESTS screen, 248
 - threshold sensitivity, 106
 - threshold squelch sensitivity, 149, 150
 - receiver pass/fail limit, 154
 - tight-squelch sensitivity, 106, 155
 - receiver pass/fail limit, 155
 - tight-squelch setting, 154
 - timebase
 - High-Stability, 17
 - tolerance for setting volume
 - receiver test parameter, 130
 - tolerance window
 - for setting volume, 130, 238
 - tone codes
 - for CTCSS, 239
 - Tone/Digital Signaling, 17
 - tone-code table
 - for CTCSS frequencies, 240
 - tone-squelch circuit, 124
 - tone-squelch opening SINAD, 149, 150
 - transceiver
 - full-rated system deviation, 115
 - transmit continuously, 138
 - transmitter
 - audio distortion, 97
 - audio distortion pass/fail limit, 158
 - audio modulation index error pass/fail limit, 159
 - audio-frequency response, 96, 133
 - battery drain, 162
 - CT/CDCSS control, 135
 - CT/CDCSS deviation pass/fail limit, 160
 - CT/CDCSS filter 1 option, 136
 - CTCSS frequency error pass/fail limit, 161
 - CTCSS/CDCSS available, 134
 - CTCSS/CDCSS deviation and frequency, 100
 - current drain, 91
 - current drain pass/fail limit, 162
 - de-emphasis, 137
 - dekey between TX tests, 138
 - deviation, 94
 - frequency deviation >3 kHz, 140
 - frequency deviation for audio band, 139
 - frequency deviation pass/fail limit, 163
 - frequency deviation test, 95
 - frequency error, 92
 - frequency error pass/fail limit, 164
 - frequency security, 144
 - harmonic distortion factor, 158
 - keying, 143
 - microphone connections for, 143
 - microphone sensitivity pass/fail limit, 165
 - microphone sensitivity test, 98
 - microphone sensitivity test parameter, 141
 - modulation limiting, 94
 - modulation limiting pass/fail limit, 166
 - output power at low switch, 142
 - output power error, 93
 - output power error pass/fail limit, 167, 168, 169, 170, 171
 - quick test, 109
 - residual modulation pass/fail limit, 173
 - residual modulation test, 99
 - user/system key the UUT, 143
 - U
 - upgrades, ordering, 17
 - usable sensitivity
 - iterative measurement of, 131
 - measured at extreme supply voltage, 152
 - output power for, 152
 - receiver pass/fail limit, 156
 - receiver test parameter, 131, 132
 - SINAD level, 131
 - two methods for testing, 104
 - usable sensitivity at extremes
 - receiver pass/fail limit, 157
 - usable sensitivity test
 - for the receiver, 104
 - USER keys, 176, 229, 248
 - user/system key the UUT
 - transmitter test parameter, 143
 - UUT keyed
 - by user or the Test Set, 143
-

V

voltage

- for extreme measurements, [93](#)
- high supply, [116](#)
- low supply, [117](#)
- when testing extreme, [116](#), [117](#)

voltage ratio

- audio distortion, [102](#)

volume

- adjusting or setting on radio, [127](#)
- can't be set, [238](#)
- control, [130](#)
- full-scale level, [238](#)
- manually setting, [130](#)
- tolerance for setting, [130](#)

volume level

- of the meter screen, [126](#)

Y

- Yes, [229](#)

Z

zero

- the current-measurement circuit, [91](#)